

TM 5-4120-341-13

TECHNICAL MANUAL

OPERATOR'S ORGANIZATIONAL,
AND DIRECT SUPPORT
MAINTENANCE MANUAL

AIR CONDITIONER
9,000 BTU/HR COOLING

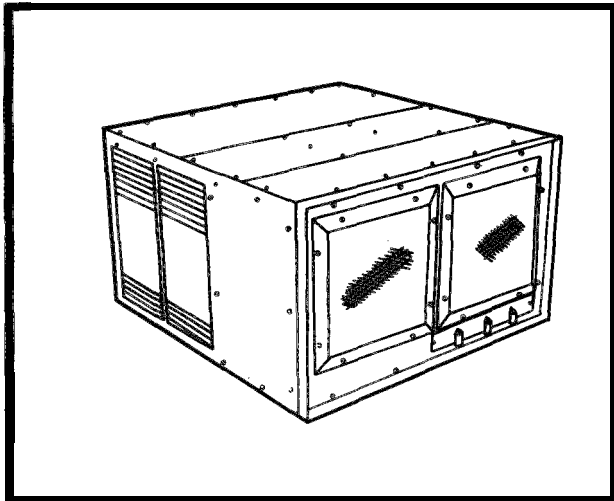

(HOTTEL MODEL HAC-751)
(4120-01-085-4732)

INTRODUCTION	1-1
OPERATING INSTRUCTION	2-1
TROUBLESHOOTING	3-1
OPERATOR'S MAINTENANCE	3-1
ORGANIZATIONAL MAINTENANCE	4-1
TROUBLESHOOTING	4-22
DS MAINTENANCE	5-1
APPENDICES	A-1
INDEX	1

HEADQUARTERS, DEPARTMENT OF THE ARMY

13 MARCH 1981

CHANGE

No. 3

HEADQUARTERS
DEPARTMENTS OF THE ARMY AND AIR FORCE
WASHINGTON, D. C., 1 JULY 1992

Operator's, Organizational, and Direct Support
Maintenance Manual

**AIR CONDITIONER
9,000 BTU/HR COOLING
(HOTTEL MODEL HAC-751)
(4120-01-085-4732)**

Approved for public release; Distribution is unlimited

TM 5-4120-341-13/TO 35E9-256-1, 13 March 1981 is changed as follows:

1. Remove and insert pages as indicated below. New or changed text material is indicated by a vertical bar in the margin. An illustration change is indicated by a miniature pointing hand.

Remove pages

5-3 through 5-10
C-5/(C-6 blank)
E-1 and E-2

Insert pages

5-3 through 5-10
C-5/(C-6 blank)
E-1 and E-2

2. Retain this sheet in front of manual for reference purposes.

By Order of the Secretaries of the Army and Air Force:

Official:

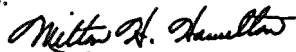

MILTON H. HAMILTON
*Administrative Assistant to the
Secretary of the Army*

01582

GORDON R. SULLIVAN
*General, United States Army
Chief of Staff*

MERRILL A. McPEAK
*General, USAF
Chief of Staff*

Official:

CHARLES C. McDONALD
*General, USAF
Commander, Air Force Logistics Command*

DISTRIBUTION:

To be distributed in accordance with DA Form 12-25E, (qty rqr block no, 0043).

CHANGE

NO. 2

HEADQUARTERS,
DEPARTMENTS OF THE ARMY AND AIR FORCE
WASHINGTON, D.C., 20 November 1990

Operator's, Organizational, and Direct Support Maintenance Manual

**AIR CONDITIONER
9,000 BTU/HR COOLING
(HOTTEL MODEL HAC-751)
(4120-01-085-4732)**

Approved for public release; distribution is unlimited

TM 5-4120-341-13, 13 March 1981, is changed as follows:

1. Remove and insert pages as indicated below. New or changed text material is indicated by a vertical bar in the margin. An illustration change is indicated by a miniature pointing hand.

Remove pages

Insert pages

2-9 through 2-11/(2-12 blank)

2-9 through 2-11/(2-12 blank)

2. Retain this sheet in front of manual for reference purposes.

By Order of the Secretaries of the Army and Air Force:

CARL E. VUONO
General, United States Army
Chief of Staff

Official:

THOMAS F. SIKORA
Brigadier General, United States Army
The Adjutant General

MERRILL A. McPEAK,
General USAF
Chief of Staff

Official:

CHARLES C. McDONALD
General, USAF
Commander, Air Force Logistics Command

DISTRIBUTION:

To be distributed in accordance with DA Form 12-25E, (qty rqr block no. 0043)

CHANGE }
No. 1 }

HEADQUARTERS, DEPARTMENTS OF
THE ARMY AND THE AIR FORCE
WASHINGTON, D.C., 21 March 1988

Operator's, Organizational, and Direct
Support Maintenance Manual

AIR CONDITIONER
9,000 BTU/HR COOLING
(HOTTEL MODEL HAC-751)
94120-01-085-4732)

TM 5-4120-341-13, 13 March 1981, is changed as follows:

1. The U.S. Air Force number is being added to this manual. All future change pages or revisions will include the U.S. Air Force.
2. Remove and insert pages as indicated below. New or changed text material is indicated by a vertical bar in the margin. An illustration change is indicated by a miniature pointing hand.

Remove pages

i and ii
F-1 and F-2

Insert pages

i and ii
F-1 and F-2
F-3/F-4

3. Retain this sheet in front of manual for reference purposes.

By Order of the Secretaries of the Army and the Air Force:

Official:

R. L. DILWORTH
Brigadier General, United States Army
The Adjutant General

CARL E. VUONO
General, United States Army
Chief of Staff

Official:

ALFRED G. HANSEN
General, USAF, Commander, Air Force
Logistics Command

LARRY E. WELSH, General USAF
Chief of Staff

DISTRIBUTION:

To be distributed in accordance with DA Form 12-25A, Operator's, Unit, Direct Support Maintenance requirements for Air Conditioner, Floor Mounted, 9,000 BTU, 3/4 HP, 60HZ, AC, 1PH (HAC-751)

WARNING

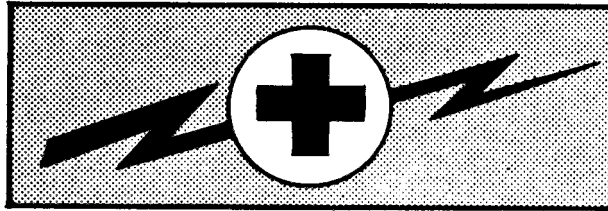

Disconnect the power source before performing any maintenance function.

Dry cleaning solvent P-D-680 or P-S-661, used to clean parts is potentially dangerous to personnel and property. Avoid repeated and prolonged skin contact. Do not use near open flame or excessive heat. Flash point of solvent is 100° F (38° C).

Death or serious injury may occur if capacitor is not discharged prior to removal.

Avoid bodily contact with liquid refrigerant and avoid inhaling refrigerant gas. Be especially careful that Refrigerant 12 does not come in contact with eyes. In case of refrigerant leaks, ventilate area immediately.

Do not use compressed air for cleaning purposes except where reduced to less than 30 psi and then only with effective chip guarding and personal protective equipment.

Purge system with dry nitrogen prior to soldering. Refrigerant heated to 1200° F creates phosgene gas.

TECHNICAL MANUAL
TM 5-4120-341-13
TO 35E9-256-1

HEADQUARTERS, DEPARTMENTS OF
THE ARMY AND THE AIR FORCE
WASHINGTON, D.C.,

**Operator's, Organizational, and Direct
Support Maintenance Manual**

**AIR CONDITIONER
9,000 BTU/HR COOLING
(HOTTEL MODEL HAC-751)
(4120-01-085-4732)**

REPORTING ERRORS AND RECOMMENDING IMPROVEMENTS

You can help improve this manual. If you find any mistakes or if you know of a way to improve the procedures, please let us know. Reports shall be submitted as follows: A reply will be furnished to you.

(A) Army - DA Form 2028 (Recommended Changes to Publications and Blank Forms), or DA Form 2028-2 located in the back of this manual direct to Commander, U. S. Army Troop Support Command, ATTN: AMSTR-MCTS, 4300 Goodfellow Boulevard, St. Louis, MO 63120-1798.

(F) Air Force - AFTO Form 22 directly to: Commander, Sacramento Air Logistics Center, ATTN: MMST, McClellan Air Force Base, CA 95652 in accordance with TO-00-5-1.

		Page
CHAPTER 1	INTRODUCTION	1-1
	CHAPTER OVERVIEW	1-1
Section I	GENERAL INFORMATION	1-1
1-1	Scope	1-1
1-2	Maintenance Forms and Records	1-1
1-3	Destruction of Army Material To Prevent Enemy Use	1-1
1-4	Reporting Equipment Improvements Recommendations (EIR's)	1-1
1-5	List of Abbreviations	1-1
1-6	Hand Receipt	1-2
Section II	EQUIPMENT DESCRIPTION	1-3
1-7	Purpose of Air Conditioner	1-3
1-8	Location and Description of Major Components	2-2
1-9	Differences Between Models	1-4
1-10	Performance Data (Organizational Maintenance)	1-4
1-11	Performance Data (Direct Support Maintenance)	1-5
Section III	TECHNICAL PRINCIPLES OF OPERATION	1-6
1-12	General	1-6
1-13	Cooling	1-6
1-14	Ventilation	1-7
CHAPTER 2	OPERATING INSTRUCTIONS	2-1
	CHAPTER OVERVIEW	2-1
Section I	PREVENTIVE MAINTENANCE CHECKS AND SERVICES (PMCS)	2-2
2-1	General	2-2
2-2	Operator/Crew Preventive Maintenance Checks and Services (PMCS)	2-2
2-3	Operating Procedures	2-6
2-4	Starting and Operating Instructions For Cooling	2-6
2-5	Starting and Operating Instructions For Ventilation	2-7
2-6	Stopping Instructions	2-8
2-7	Operating Instructions On Decals and Instruction Plates	2-9
Section II	OPERATION UNDER UNUSUAL CONDITIONS	2-10
2-8	Operation In Extreme Heat	2-10
2-9	Operation In Dusty or Sandy Areas	2-10
2-10	Operation Under Rainy or Humid Conditions	2-11

		Page
	2-11 Operation In Salt Water Areas	2-11
CHAPTER 3	OPERATOR'S MAINTENANCE INSTRUCTIONS	3-1
	CHAPTER OVERVIEW	3-1
Section I	LUBRICATION INSTRUCTIONS	3-1
3-1	Lubrication	3-1
Section II	TROUBLESHOOTING	3-1
3-2	General	3-1
3-3	Troubleshooting Table	3-1
Section III	OPERATOR'S MAINTENANCE PROCEDURES	3-2
3-4	General	3-2
3-5	Housing Panels	3-3
3-6	Air Diffuser and Return Air Grills.. ..	3-6
3-7	Control Panel Switches	3-9
CHAPTER 4	ORGANIZATIONAL MAINTENANCE INSTRUCTIONS	4-1
	CHAPTER OVERVIEW	4-1
Section I	REPAIR PARTS, SPECIAL TOOLS, TMDE, AND SUPPORT EQUIPMENT ..	4-1
4-1	Maintenance Repair Parts	4-1
4-2	Common Tools and Equipment	4-1
4-3	Special Tools and Test Equipment	4-1
4-4	Consumable Materials	4-1
Section II	SERVICE UPON RECEIPT	4-2
4-5	Service Upon Receipt Checklist	4-2
Section III	OPERATION UNDER USUAL CONDITIONS	2-4
4-6	Assembly and Preparation For Typical Use	2-4
4-7	Position the Unit	2-4
4-8	Mount the Unit	2-4
4-9	Connect the Power Source	2-5
4-10	Initial Adjustments	2-6
4-11	Fan Rotation Check	2-6
4-12	Return Air Grill Check	2-7
Section IV	PREVENTIVE MAINTENANCE CHECKS AND SERVICES	
	(PMCS) ORGANIZATIONAL	4-8
4-13	General	4-8
4-14	Preventive Maintenance Checks and Services (PMCS)	4-8
Section V	ORGANIZATIONAL TROUBLESHOOTING	4-22.1
4-15	General	4-22.1
4-16	Organizational Troubleshooting Table	4-22.1
Section VI	ORGANIZATIONAL MAINTENANCE PROCEDURES	4-25
4-17	General	4-25
4-18	Housing Panels and Grills	4-26
4-19	Air Filter	4-32
4-20	Fan Motor	4-34
4-21	Condenser Fan	4-41
4-22	Circulating Fan	4-48
4-23	Selector Switch	4-53
4-24	Thermostat Switch	4-57
4-25	Motor Capacitor	4-61
4-26	Start Capacitor	4-63
4-27	Run Capacitor	4-65
4-28	Start Relay	4-67
4-29	Wiring	4-70
4-30	Compressor	4-73
4-31	Refrigerant Piping	4-74
4-32	Evaporator Coil	4-80
4-33	Condenser Coil	4-83
4-34	Sight Glass	4-85
4-35	Expansion Valve	4-87
Section VII	PREPARATION FOR MOVEMENT	4-87

	Page
CHAPTER 5	5-1
	DIRECT SUPPORT MAINTENANCE INSTRUCTIONS
	CHAPTER OVERVIEW
Section I	REPAIR PARTS, SPECIAL TOOLS, TMDE, AND SUPPORT EQUIPMENT
5-1	Maintenance Repair Parts
5-2	Common Tools and Equipment
5-3	Special Tools and Test Equipment
5-4	Consumable Materials
Section II	DIRECT SUPPORT TROUBLESHOOTING
5-5	General
5-6	Direct Support Troubleshooting Table
Section III	DIRECT SUPPORT OPERATOR'S MAINTENANCE PROCEDURES
5-7	General
5-8	Refrigerant Servicing
5-9	Compressor
5-10	Refrigerant Piping and Service Valves
5-11	Evaporator Coil
5-12	Condenser Coil
5-13	Dehydrator
5-14	Sight Glass
5-15	Expansion Valve
	APPENDICES
APPENDIX A	REFERENCES
APPENDIX B	COMPONENTS OF END ITEM LIST
APPENDIX C	MAINTENANCE ALLOCATION CHART
APPENDIX D	ADDITIONAL ORGANIZATION LIST
APPENDIX E	EXPENDABLE SUPPLIES AND MATERIALS LIST
APPENDIX F	DIAGRAMS
	INDEX

CHAPTER 1 INTRODUCTION

CHAPTER OVERVIEW

The purpose of this chapter is two-fold:

- a. To provide you with the standard data required in all manuals (i.e. forms and record data).
- b. To acquaint you with the air conditioner. This is done by giving you a physical and functional description of those major equipment parts that you are likely to come in contact with.

Section I. GENERAL INFORMATION

1-1. SCOPE

Type of Manual: Operator's, Organizational, and Direct Support Maintenance

Model Number and Equipment Name: HAC-751 Air Conditioner: Floor Mounted, Air Cooled, Electric Motor Driven, 3/4 HP, 60 Hertz AC, Single Phase, 9,000 BTU/HR

Purpose of Equipment: Provide filtered, cooled air to a desired predetermined range and circulating the air to provide cooling of equipment or personnel within the air conditioned area.

1-2. MAINTENANCE FORMS AND RECORDS

Department of the Army forms and procedures used for equipment maintenance will be those prescribed by TM 38-750, the Army Maintenance Management Systems (TAMMS).

1-3. DESTRUCTION OF ARMY MATERIEL TO PREVENT ENEMY USE

Refer to TM 750-244-3, Procedures for Destruction of Equipment to Prevent Enemy Use, for information about destruction.

1-4. REPORTING EQUIPMENT IMPROVEMENT RECOMMENDATIONS (EIRs)

If your air conditioner needs improvement, let us know. Send us an EIR. You, the user, are the only one who can tell us what you don't like about your equipment. Let us know why you don't like the design. Tell us why a procedure is hard to perform. Put it on an SF 368 (Quality Deficiency Report). Mail it directly to Commander, U.S. Army Troop and Aviation Materiel Readiness Command, ATT: DRSTS-MEM, 4300 Goodfellow Boulevard, St. Louis, MO 63120.

1-5. LIST OF ABBREVIATIONS

a		ampere	l	liter
BTU/HR	British Thermal Units Per Hour		lb	pound
C		Celsius	OD	Outside Diameter
COMPR		Compressor	psi	pounds per square inch
DB		Dry Bulb	pt	pint
F		Fahrenheit	rpm	revolutions per minute
hpr		Horsepower	SHR	Sensible Heat Ratio
in		inch	v	volts
kg		kilogram	vac	volts alternating current
kg/m	kilograms per square meter		vdc	volts direct current

1-6. HAND RECEIPT

Hand receipts for Components of End Item (COEI), Basic Issue Items (BII), and Additional Authorization List (AAL) items are published in a Hand Receipt manual, TM 5-4120-341-13-HR. This manual is published to aid in property accountability and is available through Commander, U.S. Army Adjutant General Publication Center, ATTN: AGDL-OD, 1655 Woodson Road, St. Louis, MO 63114.

Section II. EQUIPMENT DESCRIPTION

1-7. PURPOSE OF AIR CONDITIONER

The air conditioner is used primarily in van type enclosures. The units provide filtered, cooled air, as required, to maintain the service conditions necessary for the efficient operation of electronic equipment in the vans. The air conditioners also provide for the comfort of operating personnel housed within the vans.

Capabilities and Features

Floor mounted and air cooled

Electric motor driven and designed for continuous operation under varying loads

Furnishes 9,000 BTU/HR for cooling

1. Air conditioner housing and panels
2. Fan motor and fans
3. Control panel
4. Compressor
5. Evaporator coil, expansion valves, and piping
6. Condenser coil, dehydrator, valves and piping

1-8. LOCATION AND DESCRIPTION OF MAJOR COMPONENTS

1. Return Air Grill - Adjustable and controls the amount of air passing through the air conditioner.
2. Condenser Inlet - Directs flow of air to condenser.
3. Air Diffuser Grill - Directs flow of evaporator outlet air.
4. Control Panel - Contains all control switches.
5. Power Cable - For connection to 115 volts, 60 Hz, single phase power source.

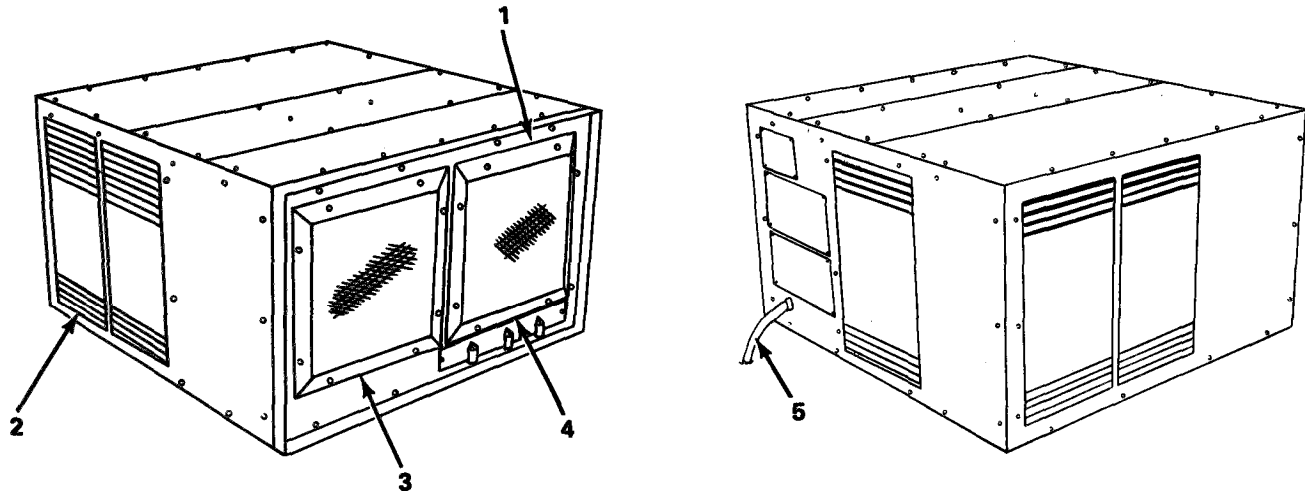

1-9. DIFFERENCES BETWEEN MODELS

This manual covers only Harvey W. Hottel, Inc. Model HAC-751.

1-10. PERFORMANCE DATA (ORGANIZATIONAL MAINTENANCE)

a. Air Conditioner, Floor Mounted, 9,000 BTU/HR, 115 Volts, Single Phase, 60 Hertz.

Manufacturer	Harvey W. Hottel, Incorporated
National Stock Number	4120-01-085-4732
Model	HAC-751
Length	27 5/8 in. (701.675mm)
Width	26 1/2 in. (673.1 mm)
Height	15 5/8 in. (396.875 mm)
Capacity	9,000 BTU/HR
Weight	153 lbs. (69.40 kg)

b. Compressor (B1).

Manufacturer	Hupp, Incorporated
Model	EH751A2556
Military Part Number	13221E4551
Volts	115
Hertz	50/60
Phase	Single
Weight (with oil)	70 pounds

c. Fan Motor (B2).

Manufacturer	Dayton Electric Mfg. Company
Model	3M064A
Military Part Number	13221E4583
Volts	115
Phase	Single
RPM	1250/1550
Horsepower	1/4
Duty	Continuous
Motor Drive	Direct
Thermal Protector	Automatic reset type open at 165° C (329° F)
Rotation (lead end)	Counterclockwise

d. Start Capacitor (C1).

Manufacturer	Cornell Dubilier Electronics
Part Number	ETW460-125
Military Part Number	13221E4581
Type	Fixed aluminum electrolytic
Capacitance	500mfd± 8%
Working Voltage	125 Vac

e. Run Capacitor (C2).

Manufacturer	General Electric Company
Part Number	21L3007
Type	Fixed paper
Capacitance	7.5 mfd
Working Voltage	.370

f. Motor Capacitor (C3) (Supplied as Part of Motor).

Manufacturer	P. R. Mallory
Part Number	32BF3703
Capacitance	3 mfd
Working Voltage	.370

g. Start Relay (K1).

Manufacturer General Electric Company
 Part Number 3ARR3B-2M5
 Military Part Number 13221E4582
 Type Voltage
 Contacts Open 140 to 153 volts at 35° C (95° F), 150 to 160 volts at 95° C (203° F)
 Contacts Close 20 to 45 volts

h. Rotary Selector Switch (S1).

Manufacturer Oak Industries, Incorporated
 Part Number 240T6HPC
 Military Part Number 13221E4549
 Type SPDT
 Number of Switch Positions 3

i. Thermostat (S2).

Manufacturer Ranco
 Part Number A30-1792
 Military Part Number 13221E4554
 Type SPST, normally closed
 Contacts Close (temp. drop) 69° F to 71° F (20.6° C to 21.7° C)

j. Expansion Valve

Manufacturer The Singer Co., Controls Division
 Part Number 223-149
 Military Part Number 13221E4574
 Inlet 1/4 ODF
 Outlet 1/2 ODF
 Cap. Tube Length 60 in. (1,524 mm)
 Nominal Capacity 1/2 ton
 Superheat (factory set) 8 1/2° F to 9 1/2° F bath temperature (-13° C to 12.5° C
 at a 0° C bath temperature)

k. Sight Glass.

Manufacturer Mueller Brass Co.
 Part Number A15966
 Military Part Number 13221E4548

1-11. PERFORMANCE DATA (DIRECT SUPPORT MAINTENANCE)

a. Dehydrator

Manufacturer Sporlan
 Part Number CO-52
 Military Part Number 13214E3557

b. Refrigerant Service Valves.

Manufacturer Robinair Mfg. Corporation
 Part Number V2S-4
 Military Part Number 13219E9499
 Valve Stem Handle for opening and closing

Section III. TECHNICAL PRINCIPLES OF OPERATION

1-12. GENERAL

The air conditioner is a floor-mounted, self-contained, electric motor driven unit that provides 9,000 BTU/HR for cooling. Once started, it operates automatically due to the relationship of the components, controls and instruments.

1-13. COOLING

With the selector switch in the COOL position the fan motor and the compressor are energized. The fan motor and compressor run continuously. The flow within the refrigerant circuit determines the cooling mode of unit. With the fan motor and compressor operating, the flow within the refrigerant circuit is controlled by the THERMOSTAT switch.

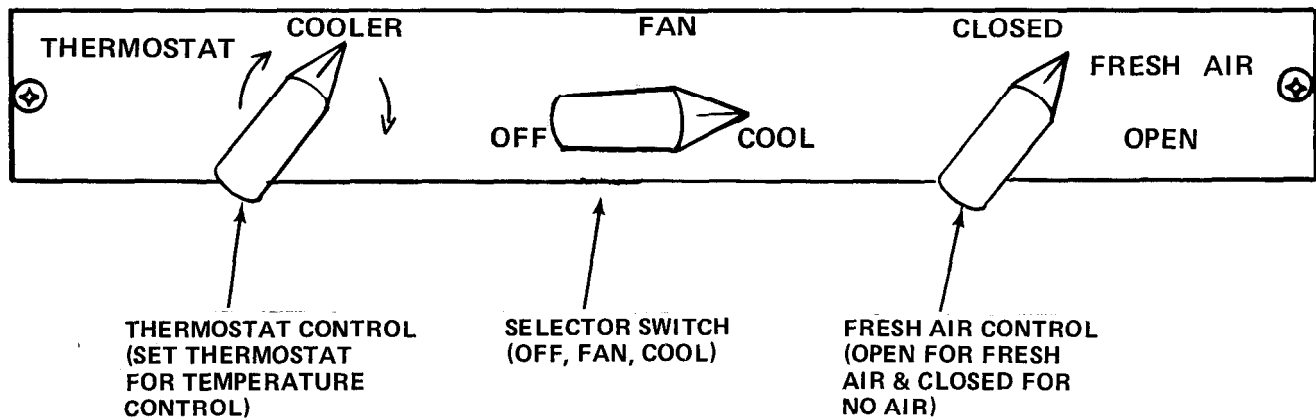

1-14. VENTILATION

Placing the selector switch in the FAN position energizes the fan motor which forces air out of the air diffuser grill. The amount of outdoor air used for ventilation is determined by the position of the FRESH AIR control.

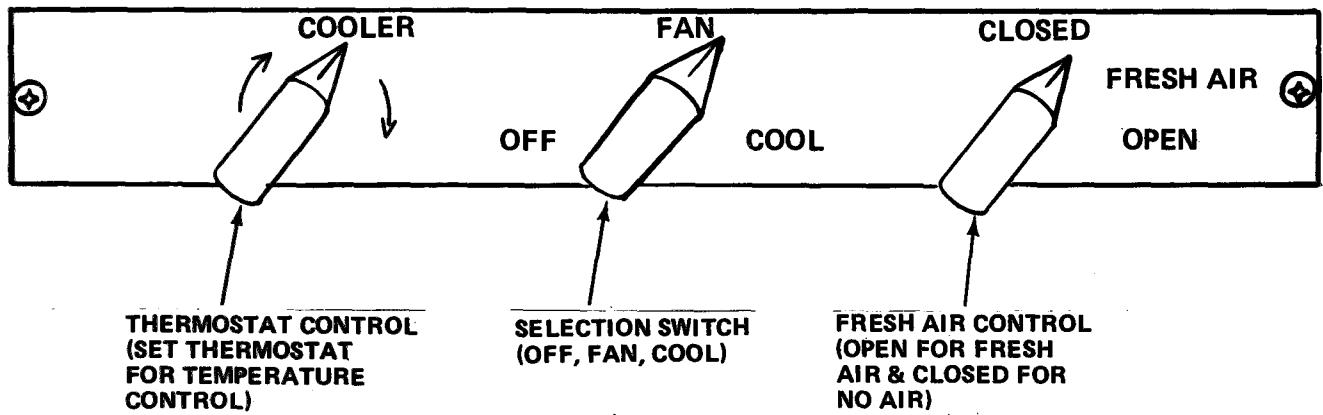

CHAPTER 2

OPERATING INSTRUCTIONS

CHAPTER OVERVIEW

This chapter contains a functional description of the major components of the air conditioner. It explains how to operate the air conditioner. For your convenience, below is an index of this chapter.

INDEX

	Para	Page
Operating Instructions on Decals and Instruction Plates	2-7	2-9
Operating Procedures	2-3	2-6
Operation Under Unusual Conditions	2-8	2-10
Preventive Maintenance Checks and Services	2-2	2-2

Section I. PREVENTIVE MAINTENANCE CHECKS AND SERVICES (PMCS)

2-1. GENERAL

Before you operate. Always keep in mind the CAUTIONS and WARNINGS. Perform (B) PMCS before you operate.

While you operate. Always keep in mind the CAUTIONS and WARNINGS. Perform (D) PMCS while you operate.

After you operate. Be sure to perform (A) PMCS after operation.

If your equipment fails to operate. Troubleshoot with proper equipment. Report any deficiencies using the proper forms, see TM 38-750.

2-2. OPERATOR/CREW PREVENTIVE MAINTENANCE CHECKS AND SERVICES (PMCS)

NOTE

If the equipment must be kept on continuous operation, check and service only those items that can be checked and serviced without disturbing operation. Make the complete checks and services when the equipment can be shut down.

NOTE: Within designated intervals, these checks are to be performed in the order listed.

B--Before

D--During

A--After

Item No.	Interval			Item to be Inspected	Procedures Check For and Have Repaired or Adjusted As Necessary	For Readiness Reporting Equipment is Not Ready/ Available If:
	B	D	A			
1	●		●	Air Diffuser Grill	Inspect for cleanliness obstructions, damage, and security of attachment. Report damaged condition to organizational maintenance personnel.	
2	●		●	Return Air Grill	Inspect for cleanliness, obstructions, damage, and security of attachment. Rotate FRESH AIR control to adjust return air grill.	

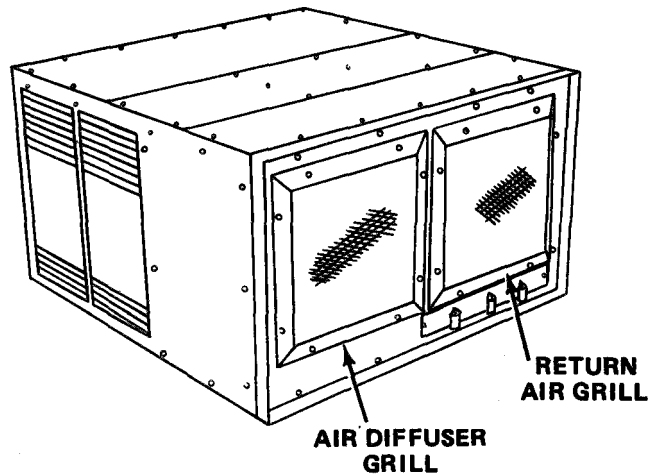

NOTE: Within designated intervals, these checks are to be performed in the order listed.

B--Before

D--During

A--After

Item No.	Interval			Item to be Inspected	Procedures Check For and Have Repaired or Adjusted As Necessary	For Readiness Reporting Equipment is Not Ready/ Available If:
	B	D	A			
3	●			Housing Panels	Inspect for security of attachment and cleanliness. Report damaged condition to organizational maintenance personnel.	
4	●			Drains	Inspect drains for obstructions. Remove obstructions as required.	

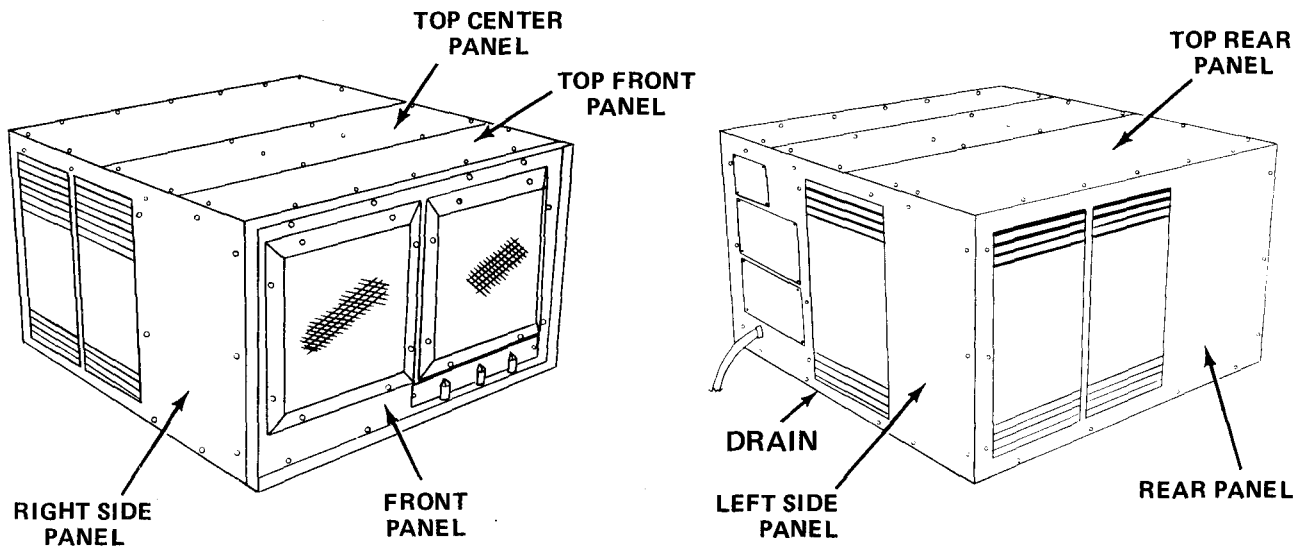

NOTE: Within designated intervals, these checks are to be performed in the order listed.

B--Before

D--During

A--After

Item No.	Interval			Item to be Inspected	Procedures Check For and Have Repaired or Adjusted As Necessary	For Readiness Reporting Equipment is Not Ready/ Available If:
	B	D	A			
5	●			Switches	Insure knobs are in place and check to see that switches function properly. Report damaged condition to organizational maintenance personnel.	

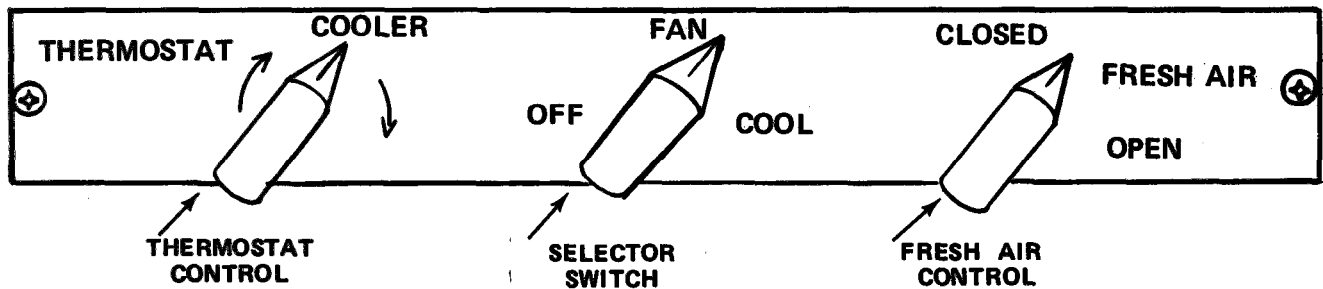

2-3. OPERATING PROCEDURES

2-4. STARTING AND OPERATING INSTRUCTIONS FOR COOLING

1. Make sure you perform the preventive maintenance checks and services (paragraph 2-2).

NOTE

Only the COOLER position for the THERMOSTAT is marked on the front panel.

2. Set THERMOSTAT control to desired temperature.
3. Place FRESH AIR control in desired position (OPEN for fresh air and CLOSED for no air).
4. Place selector switch in the FAN position to start fans.
5. Place selector switch in the COOL position. When the temperature in the area is above that of the THERMOSTAT setting, the air conditioner will provide cooling air.

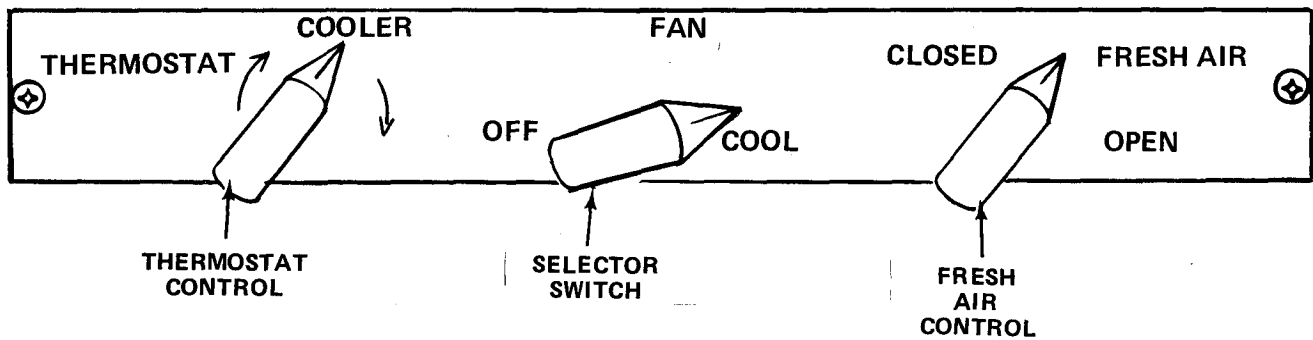

2-5. STARTING AND OPERATING INSTRUCTIONS FOR VENTILATION

1. Make sure you perform the preventive maintenance checks and services (paragraph 2-2).
2. Place FRESH AIR control in the OPEN position,
3. Place selector switch in the FAN position.

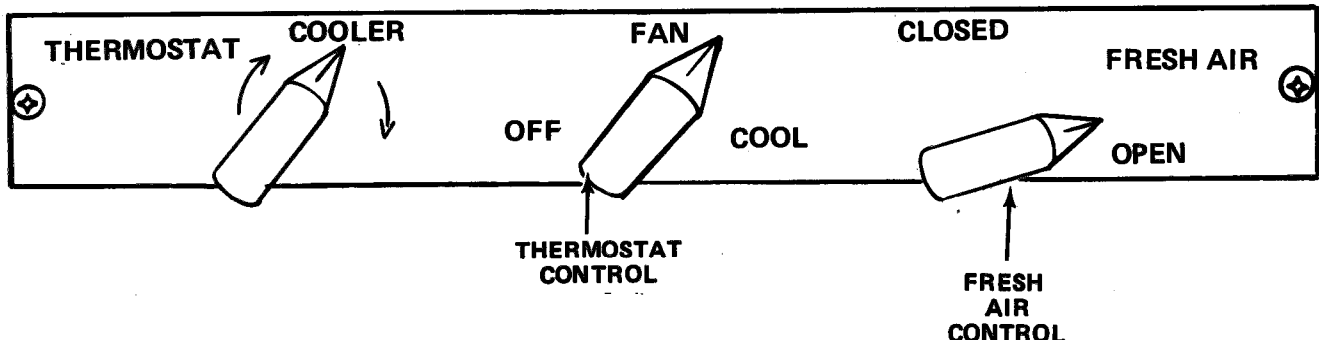

2-6. STOPPING INSTRUCTIONS

1. Place selector switch in the OFF position.
2. Place FRESH AIR control in the CLOSED position.

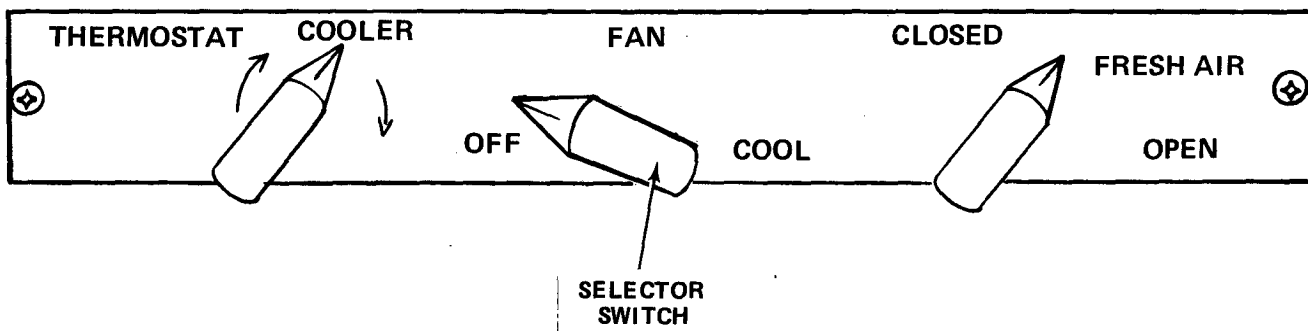

2-7. OPERATING INSTRUCTIONS ON DECALS AND INSTRUCTION PLATES

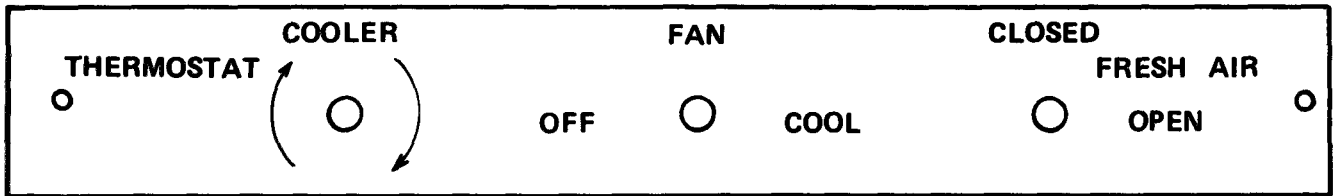

U. S. ARMY TROOP SUPPORT COMMAND	
AIR CONDITIONER: FLOOR MTG; AIR COOLED; ELECTRIC MOTOR DRIVEN, 3/4-HP AC 115V, SINGLE PHASE, 60 HZ: 9000BTU/HR	
NSN 4120-01-085-4732	
PART NO. ASSY 97403-13221E4580	
MFD BY HARVEY W. HOTTEL, INC.	
CONTRACT NO. DAAJ09-79-C-5143	
DATE	<input type="text"/>
SERIAL NO.	<input type="text"/> WT <input type="text"/> LB

Section II. OPERATION UNDER UNUSUAL CONDITIONS

2-8. OPERATION IN EXTREME HEAT

NOTE

Unit Preventive Maintenance Checks and Services (PMCS) should be performed at daily intervals.

a. General. The air conditioner is designed to operate in temperatures up to 120 °F (49 °C). Extra care should be taken to minimize the cooling load when operating in extreme high temperatures.

b. Protection.

(1) Check all openings in the enclosure, especially doors and windows, to be sure they are tightly closed. Limit in and out traffic if possible.

(2) When appropriate, use shades or awnings to shut out direct rays of the sun.

(3) When possible, limit the use of electric lights and other heat producing equipment.

(4) Limit the amount of hot, outside air introduced through the fresh air damper to that essential for ventilation.

NOTE

Weatherstripping, the installation of storm doors, and windows, if appropriate, and insulation of surfaces exposed to the outside is recommended when operating in extremely high temperatures for extended periods.

c. Cleaning.

(1) Clean outside grilles, coils, filters, and mist eliminator more frequently.

2-9. OPERATION IN DUSTY OR SANDY AREAS

NOTE

Unit Preventive Maintenance Checks and Services (PMCS) should be performed at daily intervals.

a. General. Dusty and sandy conditions can seriously reduce the efficiency of the air conditioner by clogging the air filter, mist eliminator, and coils. This will cause a restriction in the volume of airflow. Accumulation of dust or sand in the condenser coil and/or in the compressor compartment may cause overheating of the refrigeration system. Dust or sand may also clog the condensate trap and water drain lines.

CAUTION

Never operate the air conditioner without having the air filters in place.

b. Protection.

(1) Shield the air conditioner from dust as much as possible.

(2) Take advantage of any natural barriers which offer protection.

(3) Limit the amount of dusty or sandy outside air introduced through the fresh air damper.

(4) Roll down and secure the fabric cover on the back of the cabinet during periods of shutdown.

c. Cleaning.

(1) Keep the air conditioner as clean as possible.

(2) Pay particular attention to the outside grilles, condenser, filters, mist eliminator, louvers, and electrical components.

(3) In extreme conditions, daily cleaning of condenser, filters, and outside grilles may be necessary.

2-10. OPERATION UNDER RAINY OR HUMID CONDITIONS

Take special precautions to keep equipment dry. If installed outdoors, cover the equipment with a waterproof cover when it is not in use. Remove cover during dry periods. Take all necessary precautions to keep the electrical components free from moisture.

CAUTION

Make sure power is disconnected from air conditioner before touching any wiring or other electrical parts.

2-11. OPERATION IN SALT WATER AREAS

a. General. Wash the exterior and condenser section of the unit, particularly condenser air discharge louver control mechanism, with clean fresh water at frequent intervals. Be careful not to damage electrical system with water. Special attention must be given to prevent rust and corrosion.

WARNING

Disconnect power source prior to washing the air conditioner

b. Painting. Paint all exposed areas where paint has cracked, peeled or blistered or report condition to organizational maintenance. Coat all exposed areas of polished metal with a light coat of grease.

CHAPTER 3

OPERATOR'S MAINTENANCE INSTRUCTIONS

CHAPTER OVERVIEW

This chapter contains all the necessary maintenance instructions to keep your air conditioner in good repair.

INDEX

	Para	Page
Lubrication Instructions	3-1	3-1
Operator Troubleshooting	3-2	3-1
Operator Troubleshooting Table	3-3	3-1
Operator's Maintenance Procedures	3-4	3-2

Section I. LUBRICATION INSTRUCTIONS

3-1. No lubrication is required.

Section II. TROUBLESHOOTING

3-2. GENERAL

a. This section provides information useful in diagnosing and correcting unsatisfactory operation or failure of the air conditioner. Each malfunction is followed by a list of probable causes and actions to take to remedy the malfunction. You should perform the tests/inspections and corrective actions in the order listed.

b. This manual cannot list all malfunctions that may occur; nor all tests or inspections and corrective actions. If a malfunction is not listed or is not corrected by listed corrective actions, notify your supervisor.

3-3. TROUBLESHOOTING TABLE

Malfunction	Test or Inspection	Corrective Action
-------------	--------------------	-------------------

AIR CONDITIONER

1. AIR CONDITIONER FAILS TO OPERATE

- Step 1. Check to see if main power cord is plugged in.
Connect power cable to receptacle supplying 115 VAC, single phase, 60 Hz power.
- Step 2. Check to see if selector switch is in OFF position.
Place selector switch in FAN or COOL position.

2. INSUFFICIENT COOLING

- Step 1. Check to see if selector switch is in COOL position.
Place selector switch in COOL position.
- Step 2. Check to see if THERMOSTAT is in COOLER position.
Place THERMOSTAT in COOLER position.
- Step 3. Inspect air diffuser and return air grills for obstructions.
Remove obstructions from air diffuser and return air grills (para 3-6).

Section III. OPERATOR'S MAINTENANCE PROCEDURES

INDEX

	Para	Page
Air Diffuser and Return Air Grills	3-6	3-6
Control Panel Switches	3-8	3-9
Drains	3-7	3-8
General	3-4	3-2
Housing Panels	3-5	3-3

3-4. GENERAL

The following information pertains to all procedures for the operator.

INITIAL SETUP

Applicable Configurations

All

Special Environmental Conditions

None

Test Equipment

None

Special Tools

None

Personnel Required

Operator

General Safety Instructions

Disconnect the power source before performing any maintenance function. Do not use compressed air for cleaning purposes except where reduced to less than 30 psi and then only with effective chip guarding and personal protective equipment.

3-5. HOUSING PANELS

This task covers:

a. Inspection

b. Service

INITIAL SETUP

Material/Parts

- Front Panel
- Left Side Panel
- Top Front Panel
- Top Center Panel
- Top Rear Panel
- Right Side Panel
- Rear Panel
- Dry Cleaning Solvent

References
None

Troubleshooting Reference

Approximate Time Required (in minutes)
 Inspection and Service **15**
 TOTAL TIME 15

LOCATION/ITEM	REMARKS	ACTION
---------------	---------	--------

INSPECTION AND SERVICE

FRONT OF HOUSING

WARNING

Dry cleaning solvent, P-D-680 or P-S-661, used to clean parts is potentially dangerous to personnel and property. Avoid repeated and prolonged skin contact. Do not use near open flame or excessive heat. Flash point of solvent is 100° F (38° C).

- | | |
|---------------------------|--|
| <p>1. Front Panel</p> | <p>a. Brush off any loose dirt or foreign matter from front panel.</p> <p>b. Wipe off front panel with a cloth moistened with dry cleaning solvent, P-D-680 or P-S-661.</p> <p>c. Inspect front panel for security of attachment and damage.</p> <p>d. Report damaged condition to organizational maintenance personnel.</p> |
| <p>2. Left Side Panel</p> | <p>a. Brush off any loose dirt or foreign matter from left side panel.</p> <p>b. Wipe off left side panel with a cloth moistened with dry cleaning solvent, P-D-680 or P-S-661.</p> <p>c. Inspect left side panel for security of attachment and damage.</p> <p>d. Report damaged condition to organizational maintenance personnel.</p> |

LOCATION/ITEM	REMARKS	ACTION
---------------	---------	--------

INSPECTION AND SERVICE

TOP OF HOUSING

3. Top Panels

- a. Brush off any loose dirt or foreign matter from top panels.
- b. Wipe off top panels with a cloth moistened with dry cleaning solvent, P-D-680 or P-S-661.
- c. Inspect top panels for security of attachment and damage.
- d. Report damaged condition to organizational maintenance personnel.

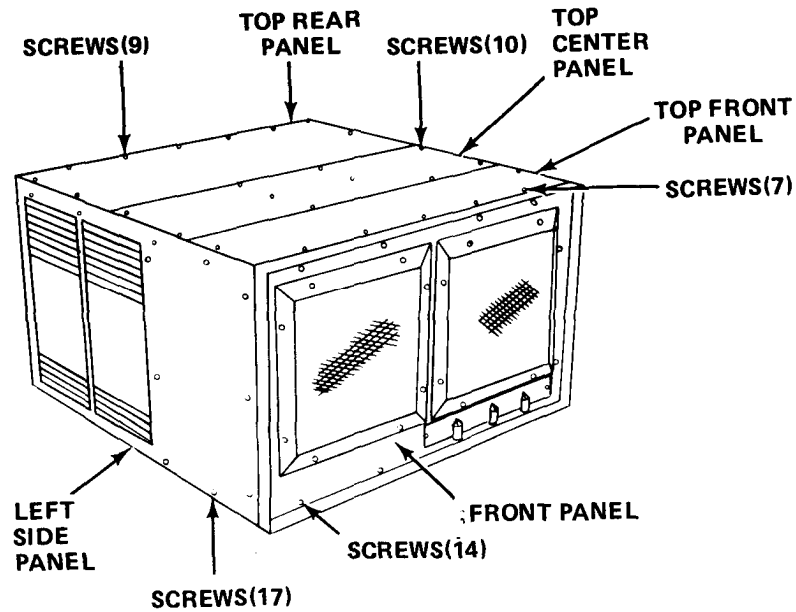

LOCATION/ITEM	REMARKS	ACTION
---------------	---------	--------

INSPECTION AND SERVICE

REAR OF HOUSING

WARNING

Dry cleaning solvent P-D-680 or P-S-661, used to dean parts is potentially dangerous to personnel and property. Avoid repeated and prolonged skin contact. Do not use near open flame or excessive heat. Flash point of solvent is 100° F (38° C).

4. Rear Panel

- a. Brush off any loose dirt or foreign matter from rear panel.
- b. Wipe off rear panel with a cloth moistened with dry cleaning solvent, P-D-680 or P-S-661.
- c. Inspect rear panel for security of attachment and damage.
- d. Report damaged condition to organizational maintenance personnel.

RIGHT SIDE OF HOUSING

5. Right Side Panel

- a. Brush off any loose dirt or foreign matter from right side panel.
- b. Wipe off right side panel with a cloth moistened with dry cleaning solvent P-D-680 or P-S-661.
- c. Inspect right side panel for security of attachment and damage.
- d. Report damaged condition to organizational maintenance personnel.

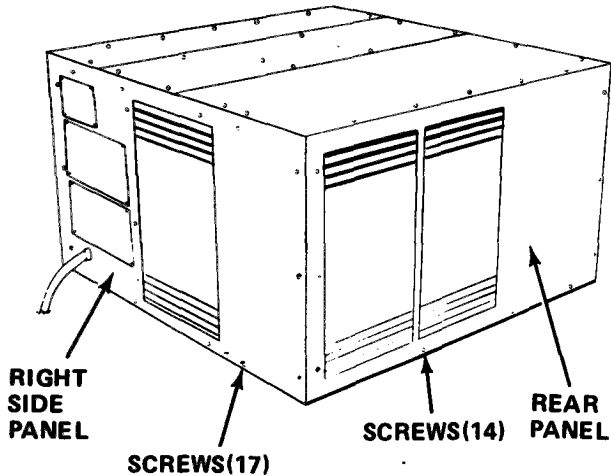

3-6. AIR DIFFUSER AND RETURN AIR GRILLS

This task covers:

- a. Inspection
- b. Service
- c. Adjustment

INITIAL SETUP

Material/Parts

- Air Diffuser Grill
- Return Air Grill
- Dry Cleaning Solvent

- References
None

Troubleshooting Reference

AIR CONDITIONER, Malfunction 2, Step 3

Approximate Time Required (in minutes)

Inspection and Service	15
Adjustment	5
TOTAL TIME	20

LOCATION/ITEM	REMARKS	ACTION
---------------	---------	--------

INSPECTION AND SERVICE

FRONT OF HOUSING

WARNING

Dry cleaning solvent, P-D-680 or P-S-661, used to clean parts is potentially dangerous to personnel and property. Avoid repeated and prolonged skin contact. Do not use near flame or excessive heat. Flash point of solvent is 100° F (38° C).

- | | |
|------------------------------|---|
| <p>1. Air Diffuser Grill</p> | <ul style="list-style-type: none"> a. Brush off any loose dirt or foreign matter from air diffuser grill. b. Wipe off air diffuser grill with a cloth moistened with dry cleaning solvent, P-D-680 or P-S-661. c. Inspect for and remove any obstructions. d. Inspect air diffuser grill for security of attachment and damage. e. Report damaged condition to organizational maintenance personnel. |
| <p>2. Return Air Grill</p> | <ul style="list-style-type: none"> a. Brush off any loose dirt or foreign matter from return air grill. b. Wipe off return air grill with a cloth moistened with dry cleaning solvent, P-D-680 or P-S-661. c. Inspect for and remove any obstructions. d. Inspect return air grill for security of attachment and damage. e. Report damaged condition to organizational maintenance personnel. |

LOCATION/ITEM	REMARKS	ACTION
---------------	---------	--------

ADJUSTMENT

FRONT OF HOUSING

3. Return Air Grill

- a. Adjust return air grill louvers by rotating fresh air control from CLOSED to FRESH AIR to OPEN positions.
- b. Verify return air grill louvers operate freely.
- c. Report damaged condition to organizational maintenance personnel.

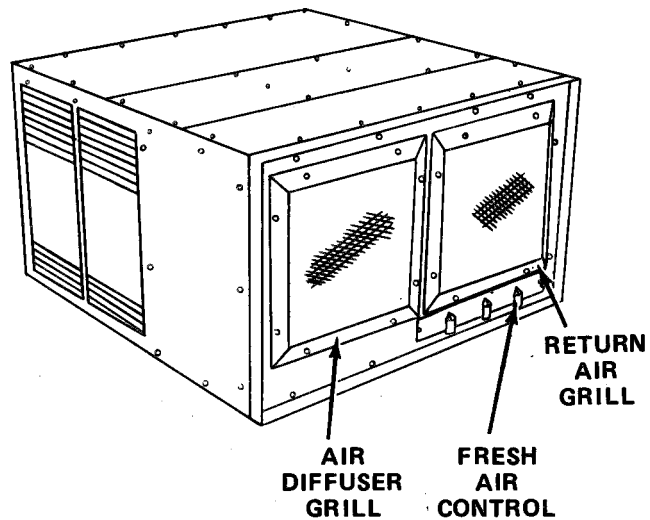

3-7. DRAINS

This task covers:

a. Inspection

b. Service

INITIAL SETUP

Material/Parts
None

Troubleshooting Reference
None

References
None

Approximate Time Required (in minutes)
Inspection and Service 5
TOTAL TIME 5

LOCATION/ITEM	REMARKS	ACTION
---------------	---------	--------

INSPECTION AND SERVICE

FRONT OR REAR

Drains

- a. Inspect drains for obstructions.
- b. Use a piece of soft wire to remove obstructions.

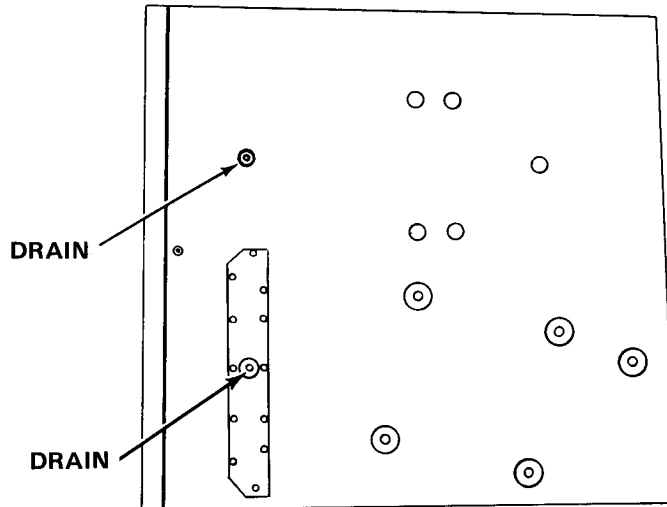

3-8. CONTROL PANEL SWITCHES

This task covers:

a. inspection

INITIAL SETUP

Material/Parts
None

Troubleshooting Reference

AIR CONDITIONER, Malfunction 1, Step 2
 AIR CONDITIONER, Malfunction 2, Step 1
 AIR CONDITIONER, Malfunction 2, Step 2

References
None

Approximate Time Required (in minutes)

Inspection	5
TOTAL TIME	5

LOCATION/ITEM	REMARKS	ACTION
---------------	---------	--------

INSPECTION

CONTROL PANEL

- | | |
|------------------------------|---|
| <p>1. Thermostat Control</p> | <p>a. Insure knob is in place and control rotates freely.
 b. Report damaged condition to organizational maintenance personnel.</p> |
| <p>2. Selector Switch</p> | <p>a. Insure knob is in place and switch moves freely from position to position and functions properly.
 b. Report damaged condition to organizational maintenance personnel.</p> |
| <p>3. Fresh Air Control</p> | <p>a. Insure knob is in place and check to see that the control moves freely between positions.
 b. Report damaged condition to organizational maintenance personnel.</p> |

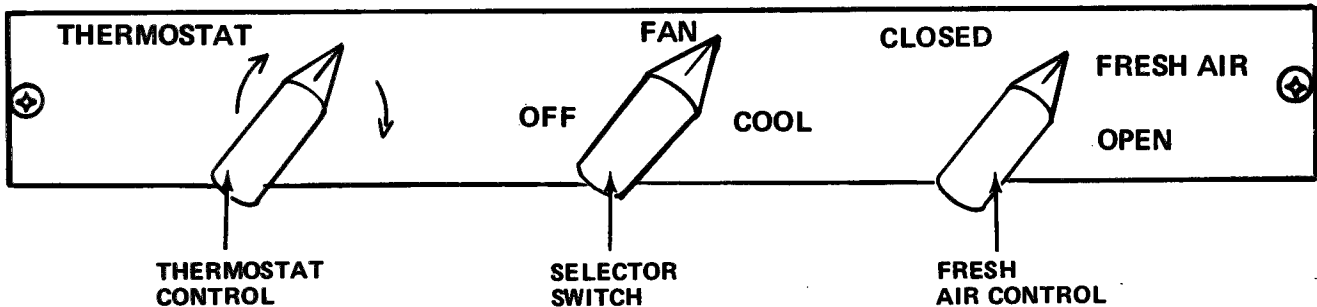

CHAPTER 4

ORGANIZATIONAL MAINTENANCE INSTRUCTIONS

CHAPTER OVERVIEW

This chapter contains all the necessary maintenance instructions for organizational maintenance personnel to keep your air conditioner in good repair.

INDEX

	Para	Page
Common Tools and Equipment	4-2	4-1
Consumable Materials	4-4	4-1
Maintenance Repair Parts	4-1	4-1
Organizational Maintenance Procedures	4-17	4-25
Organizational Troubleshooting	4-15	4-22
Organizational Troubleshooting Table	4-16	4-22
Organizational Preventive Maintenance Checks and Services (PMCS)	4-14	4-8
Preparation For Movement	4-36	4-89
Service Upon Receipt Checklist	4-5	4-2
Special Tools and Test Equipment	4-3	4-1

Section I. REPAIR PARTS, SPECIAL TOOLS, TMDE, AND SUPPORT EQUIPMENT

4-1. MAINTENANCE REPAIR PARTS

Repair parts for the air conditioner are listed and illustrated in TM 5-4120-341-23P.

4-2. COMMON TOOLS AND EQUIPMENT

For common tools and equipment refer to the Table of Organization and Equipment (TOE).

4-3. SPECIAL TOOLS AND TEST EQUIPMENT

No special tools or test equipment are required.

4-4. CONSUMABLE MATERIALS

Item No.	Name	Specification
1	Coater, Air Filter	MIL-L-2104
2	Dry Cleaning Solvent	P-D-680
3	Dry Cleaning Solvent	P-S-661
4	Adhesive	MMM-A-121

Section II. SERVICE UPON RECEIPT

4-5. SERVICE UPON RECEIPT CHECKLIST

LOCATION	ITEM	ACTION	REFERENCE
1 Exterior	Housing Panels and Grills	<ul style="list-style-type: none"> a. Inspect for signs of rough handling and damage. b. Service or reject any component if damage prevents the air conditioner from working properly. 	Paragraph 4-18
2 Front	Air Filter	<ul style="list-style-type: none"> a. Remove top front panel. b. Remove air filter and inspect the filter for accumulation of dirt. c. Clean or reject filter. 	Paragraph 4-19
3 Front	Return Air Grill	<ul style="list-style-type: none"> a. Check to see that the FRESH AIR control moves freely between the OPEN and CLOSED position and that the return air grill opens and closes properly. b. Adjust or reject FRESH AIR control. 	Paragraph 4-12
4 Front	Control Panel	<ul style="list-style-type: none"> a. Check for broken or damaged knobs. Insure that switches and controls move freely from position to position. b. Reject any component that is found to be malfunctioning. 	Paragraph 4-12
5 Right Side	Power Cable	<ul style="list-style-type: none"> a. Inspect power cable electrical connector for damage. b. Repair or reject power cable. 	Paragraph 4-9

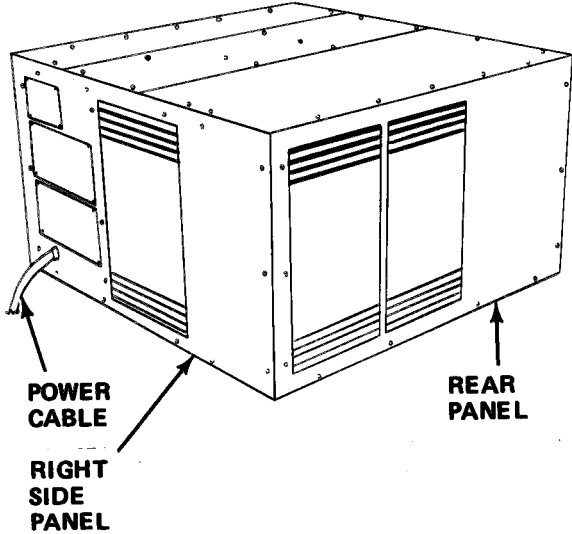
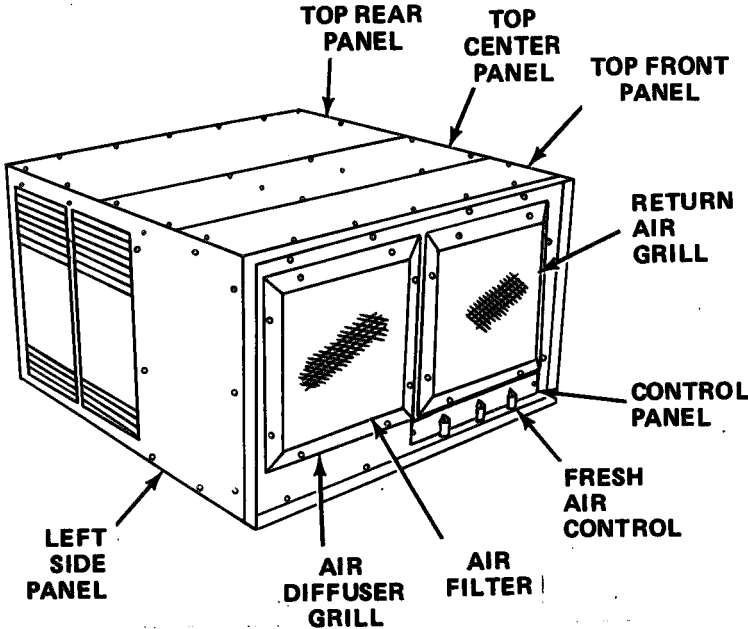

Section III. OPERATION UNDER USUAL CONDITIONS

4-6. ASSEMBLY AND PREPARATION FOR TYPICAL USE

4-7. POSITION THE UNIT

The total weight of the air conditioner is 153 pounds (69.40 kg.). Use a hand truck or fork lift of at least 200 pounds (90.8 kg.) capacity to unload the air conditioner. Keep the air conditioner upright during unloading. Pick a place that is as level as possible. Install the air conditioner in a van, shelter, or any room through an opening 15 7/8 inches (40.3225 cm) high by 26 1/4 inches (66.675 cm) long. Make sure that the air conditioner is installed so there is no restriction on the air flow, so that return air will collect the greatest amount of warm air in the space to be cooled. Make sure that the control panel is accessible to the operator and maintenance personnel.

4-8. MOUNT THE UNIT

Brace the air conditioner with two (2) brackets to resist shock. Bolt the air conditioner to the brackets using the four (4) threaded holes in the bottom of the air conditioner.

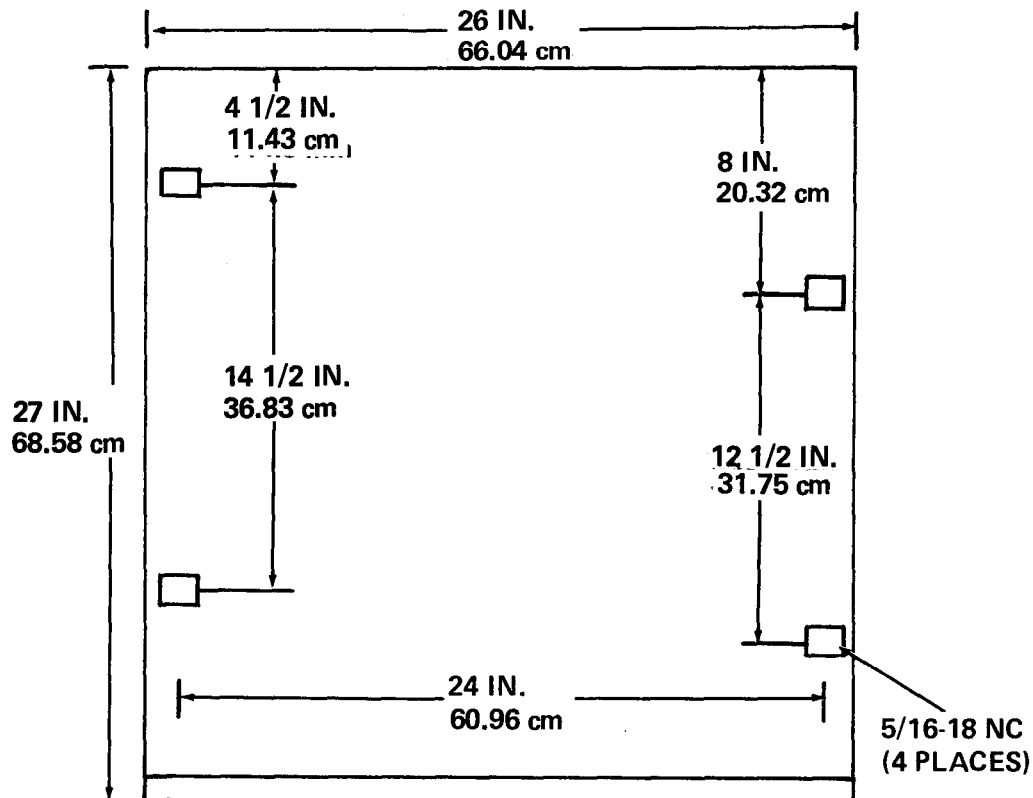

4-9. CONNECT THE POWER SOURCE

CAUTION

Make sure the selector switch is in the OFF position.

Connect the air conditioner power cable to a 115 volt, 60 hertz, single phase power source.

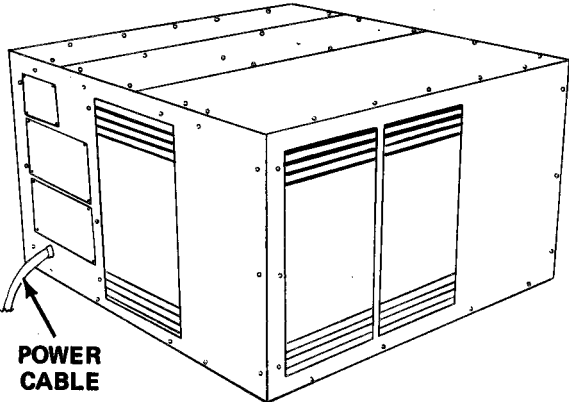
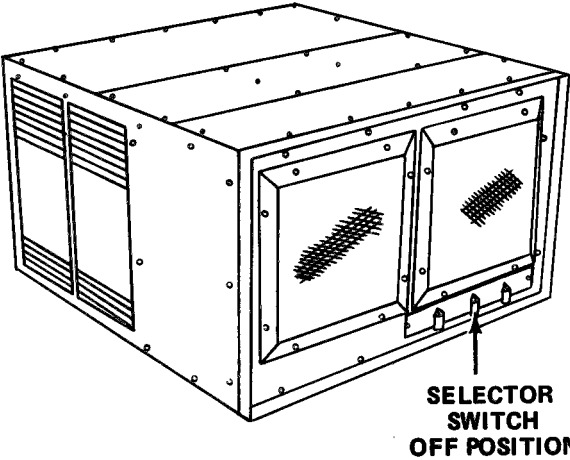

4-10. INITIAL ADJUSTMENTS

4-11. FAN ROTATION CHECK

Check for proper fan rotation as follows. Momentarily place the selector switch in the FAN position. Check to see that air is sucked through the air return grill and air is blown out through the air discharge grill.

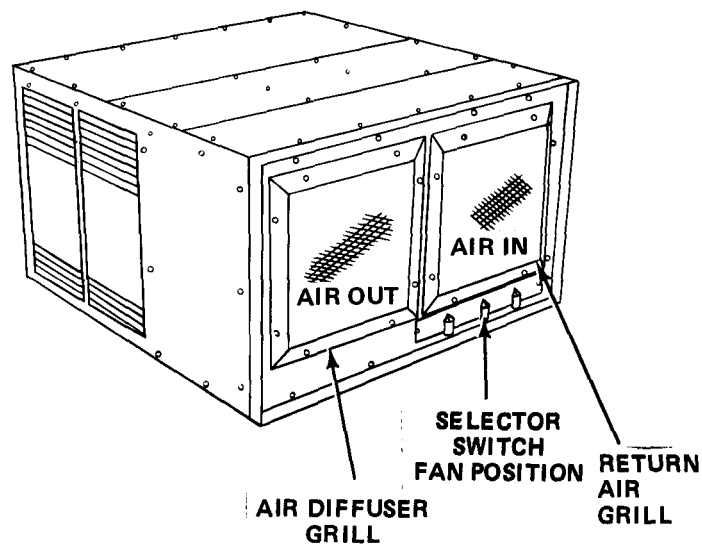

4-12. RETURN AIR GRILL CHECK

Rotate FRESH AIR control between CLOSED and OPEN positions. Make sure the return air grill louvers are closed with the FRESH AIR control in the CLOSED position and that they open with the FRESH AIR control in the OPEN position.

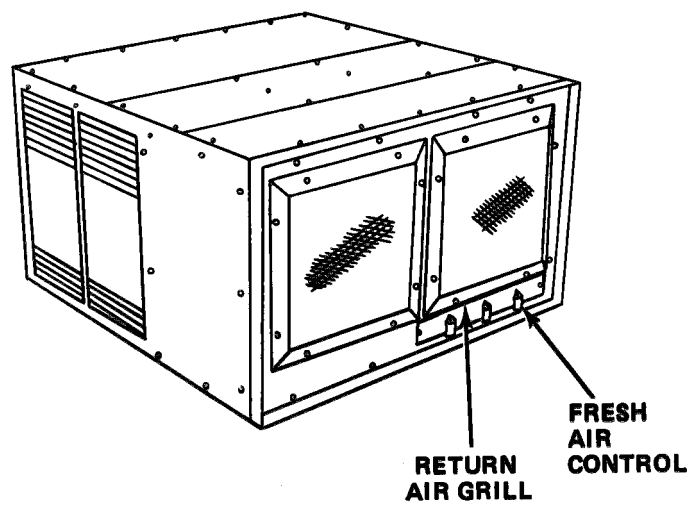

Section IV. PREVENTIVE MAINTENANCE CHECKS AND SERVICES (PMCS) ORGANIZATIONAL

4-13. GENERAL

To insure that the air conditioner is ready for operation at all times, it must be inspected systematically so that the defects may be discovered and corrected before the result is serious damage or failure. Defects discovered during operation of the unit shall be noted for future corrections to be made as soon as an operation has ceased. Stop operation which would damage the equipment if operation were to continue. All deficiencies and shortcomings shall be recorded together with the corrective action taken on DA Form 2404 "Equipment Inspection and Maintenance Worksheet", at the earliest opportunity. If your equipment fails to operate, troubleshoot with proper equipment. Report any deficiencies using proper forms, see TM 38-750.

4-14. PREVENTIVE MAINTENANCE CHECKS AND SERVICES (PMCS)

WARNING

Dry cleaning solvent, P-D-680, or P-S-661, used to clean parts is potentially dangerous to personnel and property. Avoid repeated and prolonged skin contact. Do not use near open flame or excessive heat. Flash point of solvent is 100° F (38° C).

WARNING

Do not use compressed air for cleaning purposes except where reduced to less than 30 psi and then only with effective chip guarding and personal protective equipment.

W-Weekly		Q-Quarterly	
Item No.	Interval W Q	Item To Be Inspected	Procedures Check For and Have Repaired Or Adjusted As Necessary

1 ● Air Filter

Remove twelve (12) screws securing air filter cover to bottom of air conditioner. Remove air filter cover and gasket.

Slide air filter down and out of air conditioner.

WARNING

Dry cleaning solvent, P-D-680 or P-S-661, used to clean parts is potentially dangerous to personnel and property. Avoid repeated and prolonged skin contact. Do not use near open flame or excessive heat. Flash point of solvent is 100° F (38° C).

Clean air filter with P-D-680 or P-S-661 dry cleaning solvent or warm soapy water and dry with low-pressure compressed air.

Inspect air filter for damaged or clogged condition. Replace air filter if damage is indicated.

Inspect two (2) rubber pads on bottom of air filter for damage. Replace pads if damage is indicated. Secure pads with adhesive per specification MMM-A-121.

Dip or spray air filter with filter-kote or oil per specification MIL-L-2104 Grade 20, 30 or better. Drain off excessive oil before installation.

Slide air filter up into air conditioner.

Install gasket and air filter cover and secure with twelve (12) screws

NOTE

For the following PMCS items, the air conditioner must be removed.

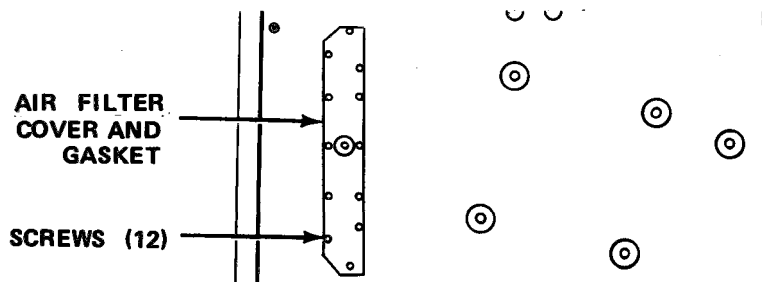

W-Weekly Q-Quarterly

Item No.	Interval W Q	Item To Be Inspected	Procedures Check For and Have Repaired Or Adjusted As Necessary	Equipment Is Not Ready/ Available If:
2	●	Fan Motor	<p>Remove seventeen (17) screws securing right side panel to housing. Remove right side panel.</p> <p>Inspect fan motor for security of attachment.</p> <p>Remove two (2) oil port caps and add SAE-20 oil every year. Replace oil port caps.</p> <p>Align holes in right side panel with holes in housing.</p> <p>Secure right side panel with seventeen (17) screws.</p>	
3	●	Fans	<p>Remove seventeen (17) screws securing right side panel to housing. Remove right side panel.</p> <p>Inspect condenser fan for cleanliness and damage.</p> <p>Inspect circulating fan for cleanliness and damage.</p>	

W-Weekly		Q-Quarterly		
Item No.	Interval W Q	Item To Be Inspected	Procedures Check For and Have Repaired Or Adjusted As Necessary	Equipment Is Not Ready/ Available If:

3 ● Fans (continued)

Align holes in right side panel with holes in housing.

Secure right side panel with seventeen (17) screws.

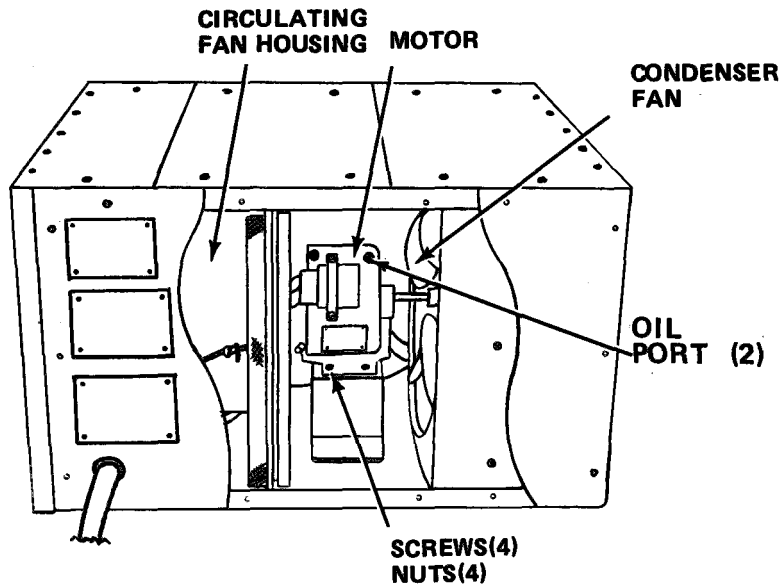

W-Weekly		Q-Quarterly		
Item No.	Interval W Q	Item To Be Inspected	Procedures Check For and Have Repaired Or Adjusted As Necessary	Equipment Is Not Ready/ Available If:

4 ● Wiring

Remove ten (10) screws securing top center panel to housing. Remove top center panel.

Remove seven (7) screws securing top front panel to housing. Remove top front panel.

Remove nine (9) screws securing top rear panel to air conditioner housing. Remove top rear panel.

Remove seventeen (17) screws securing right side panel to housing. Remove right side panel.

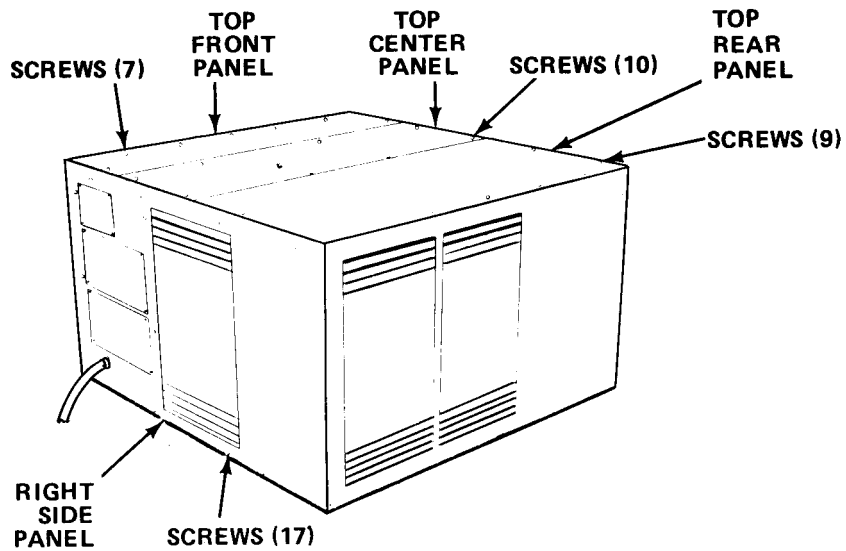

W-Weekly		Q-Quarterly		
Item No.	Interval W Q	Item To Be Inspected	Procedures Check For and Have Repaired Or Adjusted As Necessary	Equipment Is Not Ready/ Available If:
4	●	Wiring (continued)	<p>Remove seventeen (17) screws securing left side panel to housing. Remove left side panel.</p> <p>Inspect wiring insulation for cracks and frayed material. Pay particular attention to the wires passing through holes in the frame or over rough edges.</p> <p>Repair or replace damaged wiring.</p> <p>Align holes in left side panel with holes in housing. Secure left side panel with seventeen (17) screws.</p> <p>Align holes in right side panel with holes in housing. Secure right side panel with seventeen (17) screws.</p>	

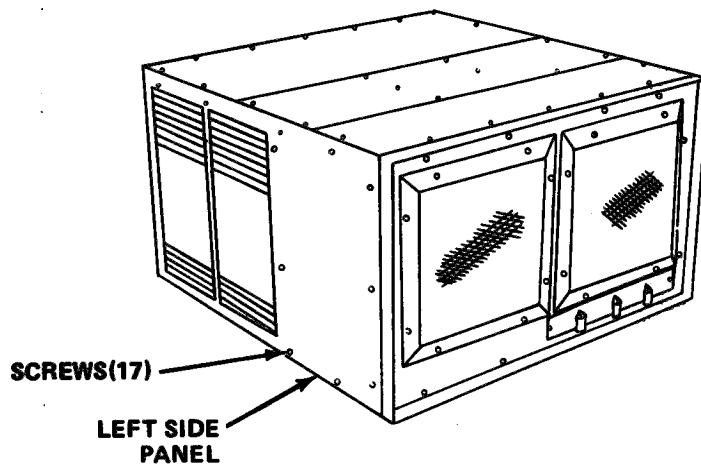

W-Weekly		Q-Quarterly			
Item No.	Interval		Item To Be Inspected	Procedures Check For and Have Repaired Or Adjusted As Necessary	Equipment Is Not Ready/ Available If:
	W	Q			
4	●		Wiring (continued)	<p>Align holes in top rear panel with holes in housing. Secure top rear panel with nine (9) screws.</p> <p>Align holes in top front panel with holes in housing. Secure top front panel with seven (7) screws.</p> <p>Align holes in top center panel with holes in top front and top rear panels. Secure top center panel with ten (10) screws.</p>	

W-Weekly

Q-Quarterly

Item No.	Interval W Q	Item To Be Inspected	Procedures Check For and Have Repaired Or Adjusted As Necessary	Equipment Is Not Ready/ Available If:
5	●	Evaporator Coil	<p>Remove eight (8) screws securing air diffuser grill to front panel. Remove air diffuser grill.</p> <p>Remove screws (17) securing left side panel to housing. Remove left side panel.</p> <p>Inspect evaporator coil for cleanliness. Use a stiff bristle brush to remove scale and corrosion from the external portion of the evaporator coil.</p> <p>Inspect evaporator coil for leaks. Report damaged condition to direct support maintenance personnel.</p> <p>Align holes in left side panel with holes in housing. Secure left side panel with seventeen (17) screws.</p> <p>Align holes in air diffuser grill with holes in front panel. Secure air diffuser grill with eight (8) screws.</p>	

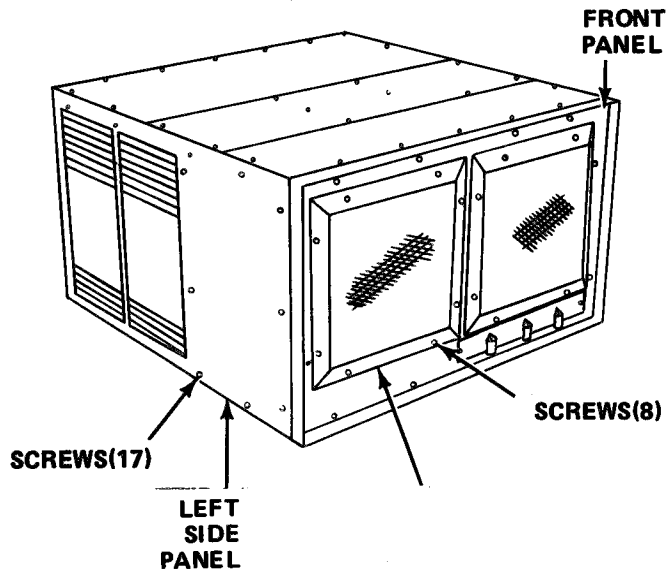

W-Weekly		Q-Quarterly		
Item No.	Interval W Q	Item To Be Inspected	Procedures Check For and Have Repaired Or Adjusted As Necessary	Equipment Is Not Ready/ Available If:
6	●	Condenser Coil	<p>Remove fourteen (14) screws securing rear panel to housing. Remove rear panel.</p> <p>Inspect condenser coil for cleanliness. Use a stiff bristle brush to remove scale and corrosion from the external portion of the condenser coil.</p> <p>Inspect condenser coil for leaks. Report damaged condition to direct support maintenance personnel.</p> <p>Align holes in rear panel with holes in housing. Secure rear panel with fourteen (14) screws.</p>	

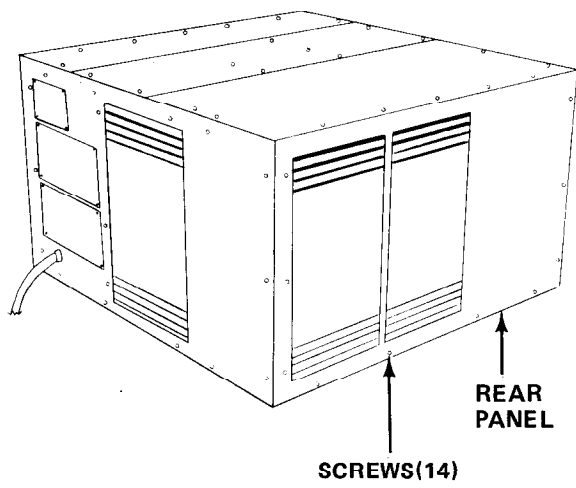

W-Weekly		Q-Quarterly		
Item No.	Interval W Q	Item To Be Inspected	Procedures Check For and Have Repaired Or Adjusted As Necessary	Equipment Is Not Ready/ Available If:

7

●

Expansion Valve and Refrigerant Piping

Remove ten (10) screws securing top center panel to housing. Remove top center panel.

Remove seven (7) screws securing top front panel to housing. Remove top front panel.

Remove nine (9) screws securing top rear panel to air conditioner housing. Remove top rear panel.

Remove seventeen (17) screws securing right side panel to housing. Remove right side panel.

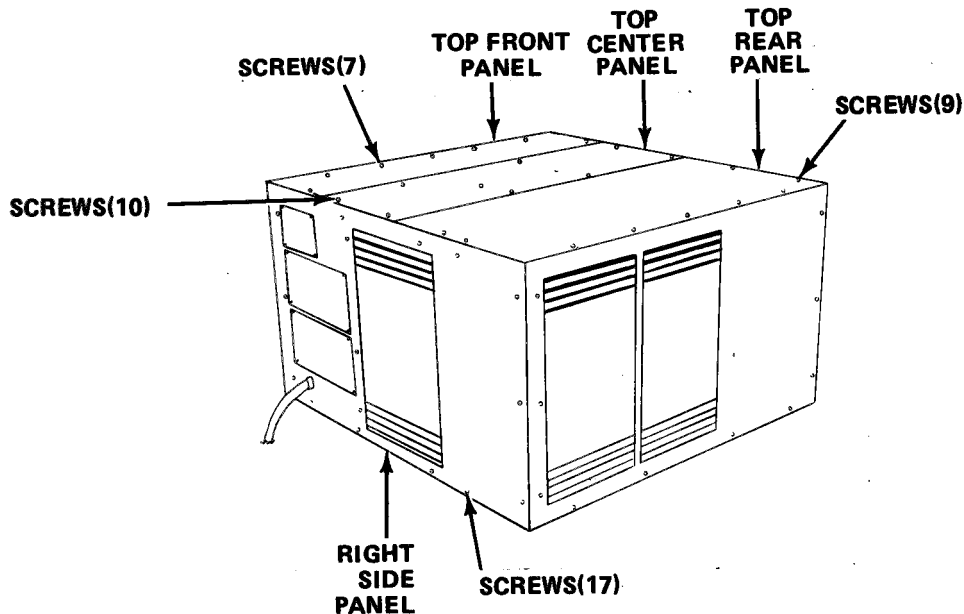

W-Weekly

Q-Quarterly

Item No.	Interval W Q	Item To Be Inspected	Procedures Check For and Have Repaired Or Adjusted As Necessary	Equipment Is Not Ready/ Available If:
7	●	Expansion Valve and Refrigerant Piping (continued)	Remove seventeen (17) screws securing left side panel to housing. Remove left side panel.	

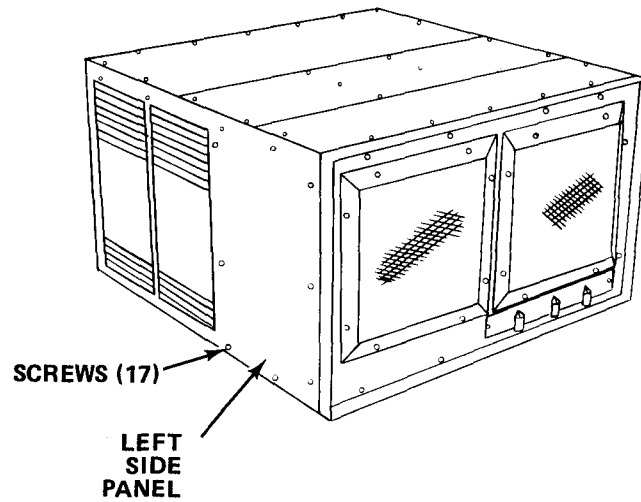

W-Weekly

Q-Quarterly

Item No.	Interval		Item To Be Inspected	Procedures Check For and Have Repaired Or Adjusted As Necessary	Equipment Is Not Ready/ Available If:
	W	Q			
7	●		Expansion Valve and Refrigerant Piping (continued)	<p>Inspect refrigerant piping for leaks. Repair leaks.</p> <p>Inspect expansion valve for loose or leaking connections. Tighten connections.</p> <p>Check to see that the sensing bulb is securely fastened and is completely covered with insulation tape part number 165 manufactured by Pressite Division, Inmont, Inc., St. Louis, MO.</p>	

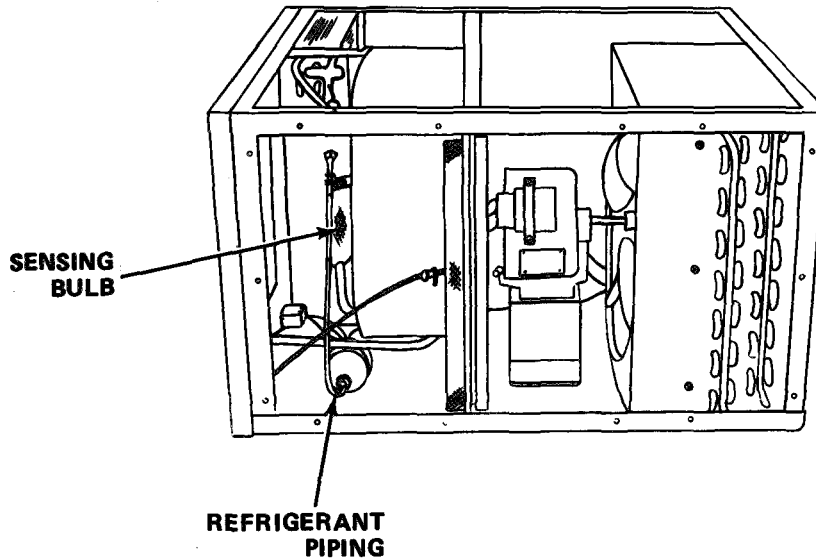

W-Weekly		Q-Quarterly		
Item No.	Interval W Q	Item To Be Inspected	Procedures Check For and Have Repaired Or Adjusted As Necessary	Equipment Is Not Ready/ Available If:
7	●	Expansion Valve and Refrigerant Piping (continued)	<p>Align holes in left side panel with holes in housing. Secure left side panel with seventeen (17) screws.</p> <p>Align holes in right side panel with holes in housing. Secure right side panel with seventeen (17) screws.</p> <p>Align holes in top rear panel with holes in housing. Secure top rear panel with nine (9) screws.</p> <p>Align holes in top front panel with holes in housing. Secure top front panel with seven (7) screws.</p> <p>Align holes in top center panel with holes in top front and top rear panels. Secure top center panel with ten (10) screws.</p> <p style="text-align: center;">NOTE</p> <p>The sight glass maybe inspected by looking through the louvers in the left side panel. If you cannot see the sight glass through the left side panel, then remove the rear panel.</p>	

W-Weekly **Q-Quarterly**

Item No.	Interval W Q	Item To Be Inspected	Procedures Check For and Have Repaired Or Adjusted As Necessary	Equipment Is Not Ready/ Available If:
8	●	Sight Glass	<p>Remove fourteen (14) screws securing panel to housing and remove rear panel.</p> <p>With the air conditioner operating and providing cooling air, inspect sight glass.</p> <p>Yellow appearance indicates moisture in system and bubbles or milky flow indicate low refrigerant charge.</p> <p>Report presence of these conditions to direct support maintenance personnel.</p> <p>Align holes in rear and with holes in housing. Secure rear panel with fourteen (14) screws.</p>	

Section V. ORGANIZATIONAL TROUBLESHOOTING

4-15. GENERAL

a. This section provides information useful in diagnosing and correcting unsatisfactory operation or failure of the air conditioner. Each malfunction is followed by a list of probable causes and actions to take to remedy the malfunction. You should perform the tests/inspections and corrective actions in the order listed.

b. This manual cannot list all malfunctions that may occur; nor all tests or inspections and corrective actions. If a malfunction is not listed or is not corrected by listed corrective actions, notify your supervisor.

4-16. ORGANIZATIONAL TROUBLESHOOTING TABLE

Malfunction	Test or Inspection	Corrective Action
AIR CONDITIONER		
1. AIR CONDITIONER FAILS TO OPERATE		
Step 1.	Check to see if main power cord is plugged in.	Connect power cable to receptacle supplying 115 VAC, single phase, 60 Hz power.
Step 2.	Check to see if power receptacle connector is defective.	Replace defective power receptacle connector (para. 4-29).
Step 3.	Check for loose electrical connections.	Tighten electrical connections.
Step 4.	Inspect for defective wiring.	Replace defective wiring. Use identical type wire, consult Appendix F, and solder all terminal connections (para. 4-29).
Step 5.	Check the selector switch.	<p>a. Observe position of the switch. Be sure switch is NOT in the OFF position.</p> <p>b. Rotate the switch through all operating positions. If the air conditioner will operate in some but not all operating positions, check for a defective switch using a multimeter.</p> <p>Replace defective switch (para. 4-23).</p>
2. INSUFFICIENT COOLING		
Step 1.	Inspect sight glass for proper amount of refrigerant (para. 4-34).	Report condition to direct support maintenance personnel.
Step 2.	Check for dirty air filter.	Clean or replace air filter (para. 4-19).
Step 3.	Inspect evaporator coil for cleanliness.	Clean evaporator coil (para. 4-32).
Step 4.	Check compressor for proper operation (para. 4-30).	Report condition to direct support maintenance personnel.
Step 5.	Inspect for closed, bent or stuck louvers in the return air grill.	Open louvers, straighten bent louvers or replace damaged return air grill (para 4-18).
Step 6.	Check to see that circulating fan is securely mounted on motor shaft and that there is no indication of damage to circulating fan.	Tighten setscrews in hub of circulating fan or replace damaged circulating fan (para 4-22).

3. EXCESSIVE NOISE

- Step 1.* Inspect circulating fan for damage and security of attachment.
Tighten setscrews in hub of circulating fan and any other loose mounting hardware or replace damaged circulating fan (para. 4-22).
- Step 2.* Inspect condenser fan for damage and security of attachment.
Tighten setscrews in hub of condenser fan and any other loose mounting hardware or replace damaged condenser fan (para. 4-21).
- Step 3.* Inspect fan motor for wear and damage.
Replace damaged fan motor (para. 4-20).
- Step 4.* Check to see if compressor is knocking or chattering.
Stop air conditioner and report condition to direct support maintenance personnel.

FANS

1. CIRCULATING FAN FAILS TO OPERATE

- Step 1.* Check to see if main power cord is plugged in.
Connect power cord to receptacle supplying 115 VAC, single phase, 60 Hz power.
- Step 2.* Test fan motor for resistance.
Consult Appendix F and replace fan motor if damage is indicated (para 4-20).
- Step 3.* Check circulating fan for damage or binding.
Relieve binding or replace damaged circulating fan (para. 4-22).
- Step 4.* Test fan motor capacitor for continuity leakage and capacitance.
Replace capacitor if damage is indicated (para. 4-25).

2. CONDENSER FAN FAILS TO OPERATE

- Step 1.* Check to see if main power cord is plugged in.
Connect power cord to receptacle supplying 115 VAC, single phase, 60 Hz power.
- Step 2.* Test fan motor for resistance.
Consult Appendix F and replace fan motor if damage is indicated (para. 4-20).
- Step 3.* Check condenser fan for damage or binding.
Relieve binding or replace damaged circulating fan (para. 4-21).
- Step 4.* Test fan motor capacitor for continuity leakage and capacitance.
Replace capacitor if damage is indicated (para. 4-25).

COMPRESSOR

1. COMPRESSOR WILL NOT START

- Step 1.* Check the selector switch.
- a. Observe position of the switch. Be sure switch is NOT in the OFF or FAN positions.
 - b. Place the switch in the COOL position. If the air conditioner will not operate in the COOL position, check for a defective switch using a multimeter.
- Replace defective switch (para. 4-23).**
- Step 2.* Check the THERMOSTAT.
- a. Observe position of the THERMOSTAT. Be sure THERMOSTAT is in the COOLER position.
 - b. Rotate THERMOSTAT to the COOLER position. If the compressor will not start, check for a defective THERMOSTAT using a multimeter.
- Replace defective THERMOSTAT (para. 4-29).**
- Step 3.* Check for loose electrical connections.
Tighten loose electrical connections.
- Step 4.* Inspect for defective wiring.
Replace defective wiring. Use identical type wire, consult Appendix F, and solder all terminal connections (para. 4-29).
- Step 5.* Check start relay for continuity.
Replace start relay if continuity is not indicated (para. 4-28).
- Step 6.* Check compressor for proper operation and damage (para. 4-30).
Report condition to direct support maintenance personnel.

2. COMPRESSOR STARTS BUT GOES OUT ON OVERLOAD

- Step 1.* Test run capacitor for continuity, leakage and capacitance.
Replace capacitor if damage is indicated (para. 4-27).
- Step 2.* Test fan motor for resistance.
Consult Appendix F and replace fan motor if damage is indicated (para 4-20).
- Step 3.* Check expansion valve for proper operation and damage (para. 4-33).
Report condition to direct support maintenance personnel.
- Step 4.* Check compressor for proper operation and damage (para. 4-30).
Report condition to direct support maintenance personnel.

AIR OUTPUT

1. EVAPORATOR AIR OUTPUT VOLUME LOW

- Step 1.* Inspect return air and air diffuser grills for damage and cleanliness.
Clean, repair or replace return air and air diffuser grills (para. 4-18).
- Step 2.* Inspect evaporator coil for damage, ice and cleanliness.
Clean evaporator coil (para. 4-32). Report damaged condition to direct support maintenance personnel.
- Step 3.* Inspect circulating fan for security of attachment and damage.
Tighten setscrews in hub of circulating fan, replace fan if damage is indicated (para. 4-22).
- Step 4.* Test fan motor for resistance.
Consult Appendix F and replace fan motor if damage is indicated (para. 4-20).

2. CONDENSER AIR OUTPUT VOLUME LOW

- Step 1.* Inspect condenser coil for cleanliness or damage.
Clean condenser coil (para. 4-33). Report damaged condition to direct support maintenance personnel.
 - Step 2.* Test thermostat for resistance.
Replace defective thermostat (para. 4-24).
 - Step 3.* Inspect condenser fan for security of attachment and damage.
Tighten setscrews in hub of condenser fan, replace fan if damage is indicated (para. 4-21).
 - Step 4.* Test fan motor for resistance.
Consult Appendix F and replace fan motor if damage is indicated (para. 4-20).
-

Section VI. ORGANIZATIONAL MAINTENANCE PROCEDURES

Section V. ORGANIZATIONAL MAINTENANCE PROCEDURES

INDEX

	Para	Page
Air Filter	4-19	4-34
Circulating Fan	4-22	4-48
Compressor	4-30	4-73
Condenser Coil	4-33	4-83
Condenser Fan	4-21	4-41
Evaporator Coil	4-32	4-80
Expansion Valve	4-35	4-87
Fan Motor	4-20	4-34
General	4-17	4-25
Housing Panels and Grills	4-18	4-26
Motor Capacitor	4-25	4-61
Refrigerant Piping	4-31	4-74
Run Capacitor	4-27	4-65
Selector Switch	4-23	4-53
Sight Glass	4-34	4-85
Start Capacitor	4-26	4-63
Start Relay	4-28	4-67
Thermostat Switch	4-24	4-57
Wiring	4-29	4-70

4-17. GENERAL

The following information pertains to all procedures for organizational maintenance personnel.

INITIAL SETUP

Applicable configurations
All

Special Environmental Conditions
None

Test Equipment
None

Special Tools
None

General Safety Instructions

Disconnect the power source before performing any maintenance function. Do not use compressed air for cleaning purposes except where reduced to less than 30 psi and then only with effective chip guarding and personal protective equipment.

Personnel Required
Organizational Maintenance

4-18. HOUSING PANELS AND GRILLS

This task covers:

- a. Removal
- b. Repair

c. Installation

INITIAL SETUP

Material/Parts

- Top Center Panel Screws (10)
- Top Front Panel Screws (7)
- Top Rear Panel Screws (9)
- Right Side Panel Screws (17)
- Rear Panel Screws (14)
- Return Air Grill Screws (8)
- Air Diffuser Grill Screws (8)
- Control Panel Plate Screws (2)
- Front Panel Screws (14)
- Adhesive

References

None

Troubleshooting Reference

Approximate Time Required (in minutes)

Removal	30
Repair	30
Installation	30
TOTAL TIME	90

LOCATION/ITEM	REMARKS	ACTION
---------------	---------	--------

REMOVAL

TOP AND LEFT SIDE OF HOUSING

1. Top Center Panel
 - a. Remove ten (10) screws securing top center panel.
 - b. Remove top center panel.
2. Top Front Panel
 - a. Remove seven (7) screws securing top front panel.
 - b. Remove top front panel.
3. Top Rear Panel
 - a. Remove nine (9) screws securing top rear panel.
 - b. Remove top rear panel.
4. Left Side Panel
 - a. Remove seventeen (17) screws securing left side panel.
 - b. Remove left side panel.

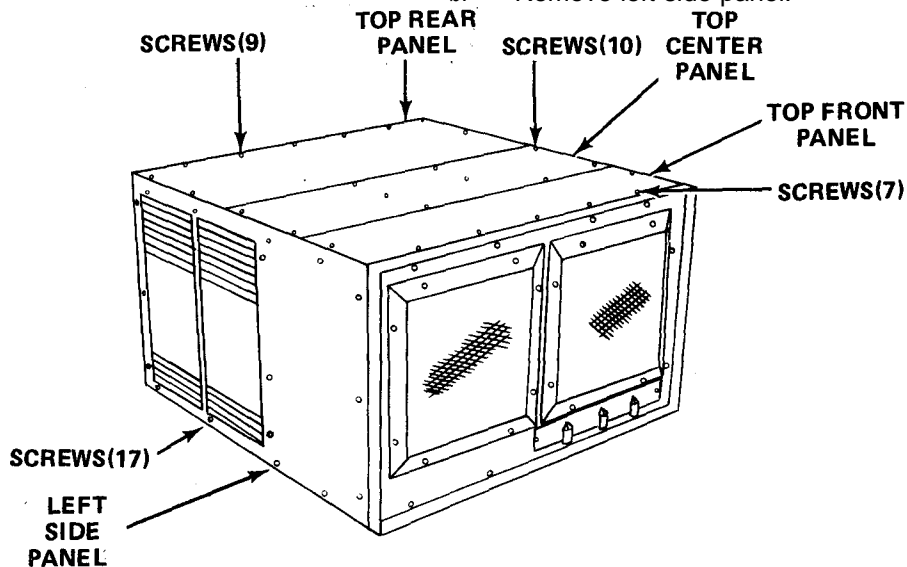

LOCATION/ITEM	REMARKS	ACTION
---------------	---------	--------

REMOVAL

RIGHT SIDE AND REAR OF HOUSING

- | | |
|---------------------|---|
| 5. Right Side Panel | <ul style="list-style-type: none"> a. Remove seventeen (17) screws securing right side panel. b. Remove right side panel. |
| 6. Rear Panel | <ul style="list-style-type: none"> a. Remove fourteen (14) screws securing rear b. Remove rear panel. |

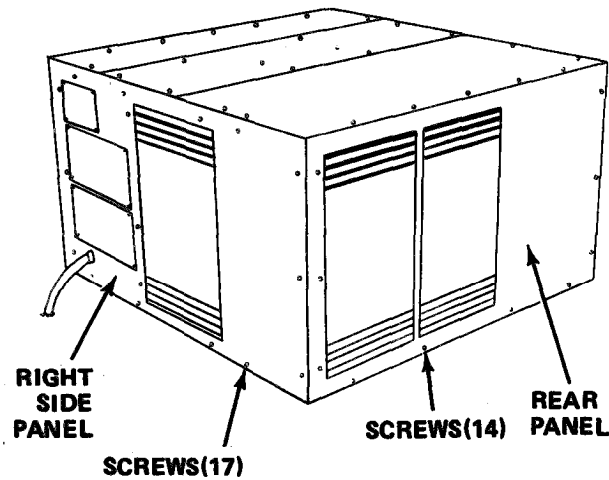

REMOVAL

FRONT OF HOUSING

- | | |
|-----------------------|--|
| 7. Return Air Grill | <ul style="list-style-type: none"> a. Loosen mechanical screw post at rear of return air grill and remove wire. b. Remove eight (8) screws securing return air grill. c. Remove return air grill. |
| 8. Air Diffuser Grill | <ul style="list-style-type: none"> a. Remove eight (8) screws securing air diffuser grill. b. Remove air diffuser grill. |

LOCATION/ITEM	REMARKS	ACTION
REMOVAL		
FRONT OF HOUSING		
9. Control Panel Plate	<ul style="list-style-type: none"> a. Loosen setscrews and remove knobs from fresh air control, selector switch and thermostat switch. b. Remove two (2) screws securing control panel plate. c. Remove control panel plate. 	
10. Front Panel	<ul style="list-style-type: none"> a. Remove two (2) screws securing thermostat switch to front panel. b. Remove fourteen (14) screws securing front panel. c. Remove front panel. 	

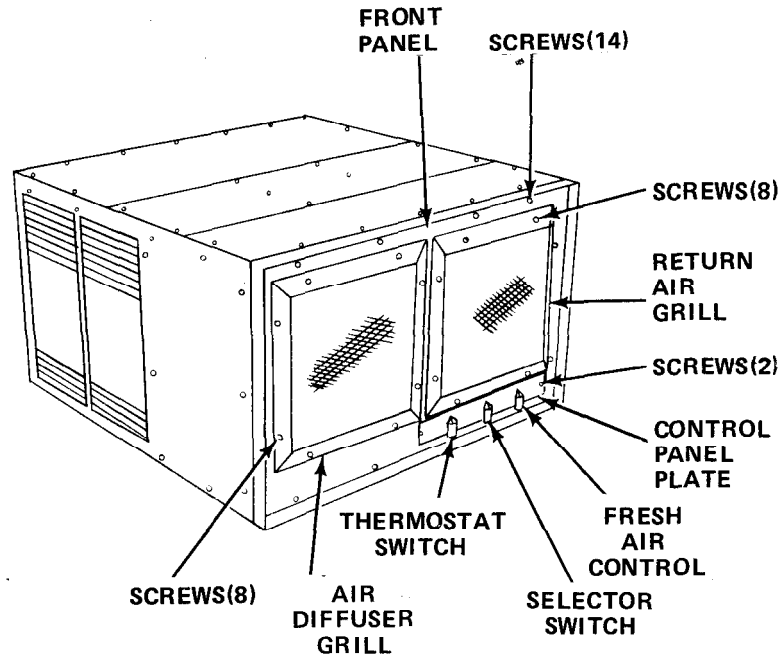

LOCATION/ITEM	REMARKS	ACTION
REPAIR		
11. Front Panel		<ul style="list-style-type: none"> <i>a.</i> Inspect floating self-locking nuts for damage. <i>b.</i> Drill out blind rivets, then rivet new nut to front panel.
12. Right Side, Left Side and Rear Panels		Repair consists of straightening bent louvers.
13. Top Front and Rear Panels		<ul style="list-style-type: none"> <i>a.</i> Inspect self-locking plate nuts for damage. <i>b.</i> Drill out blind rivets, then rivet new nut to top front panel. <i>c.</i> Inspect panels for distortion or loose gasket. <i>d.</i> Secure loose gasket with adhesive per specification MMM-A-121. <i>e.</i> replace gasket with .062 inch thick wool felt per specification MIL-G-20241. Secure gasket with adhesive per specification MMM-A-121.
14. Top Center Panel		<ul style="list-style-type: none"> <i>a.</i> Inspect panel for distortion. <i>b.</i> Straighten or replace damaged panel.
15. Grills		Repair consists of straightening bent louvers.
INSTALLATION		
FRONT OF HOUSING		
16. Front Panel		<ul style="list-style-type: none"> <i>a.</i> Align holes in thermostat switch with holes in front panel. <i>b.</i> Secure thermostat switch to front panel with two (2) screws. <i>c.</i> Align holes in front panel with holes in housing. <i>d.</i> Secure front panel with fourteen (14) screws.
17. Control Panel Plate		<ul style="list-style-type: none"> <i>a.</i> Align holes in control panel plate with holes in front panel. <i>b.</i> Secure control panel plate with two (2) screws. <i>c.</i> Install three (3) knobs.
18. Air Diffuser Grill		<ul style="list-style-type: none"> <i>a.</i> Align holes in air diffuser grill with holes in front panel. <i>b.</i> Secure air diffuser grill with eight (8) screws.
19. Return Air Grill		<ul style="list-style-type: none"> <i>a.</i> Align holes in return air grill with holes in front panel. <i>b.</i> Secure return air grill with eight (8) screws. <i>c.</i> Install wire in mechanical screw post and tighten mechanical screw post.

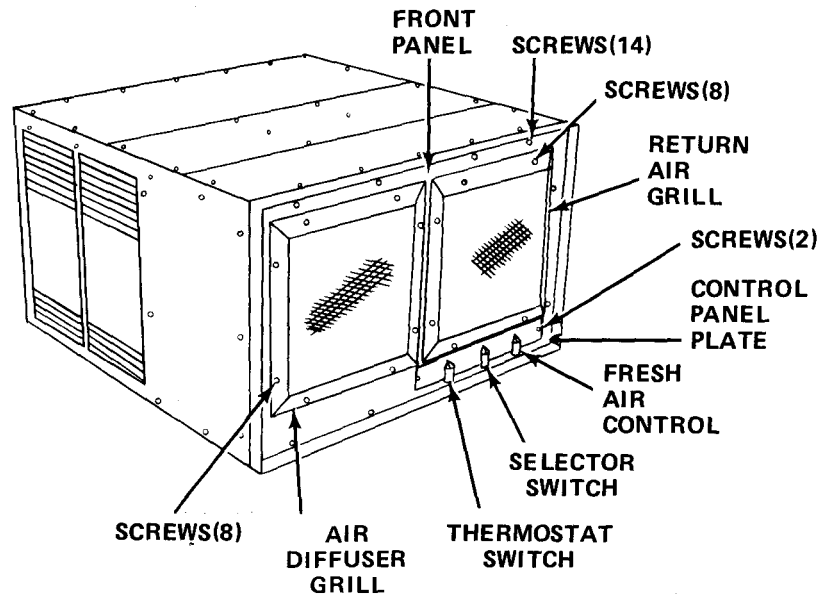

LOCATION/ITEM	REMARKS	ACTION
INSTALLATION		
RIGHT SIDE AND REAR OF HOUSING		
20. Rear Panel		<ul style="list-style-type: none"> a. Align holes in rear panel with holes in housing. b. Secure rear panel with fourteen (14) screws.
21. Right Side Panel		<ul style="list-style-type: none"> a. Align holes in right side panel with holes in housing. b. Secure right side panel with seventeen (17) screws.

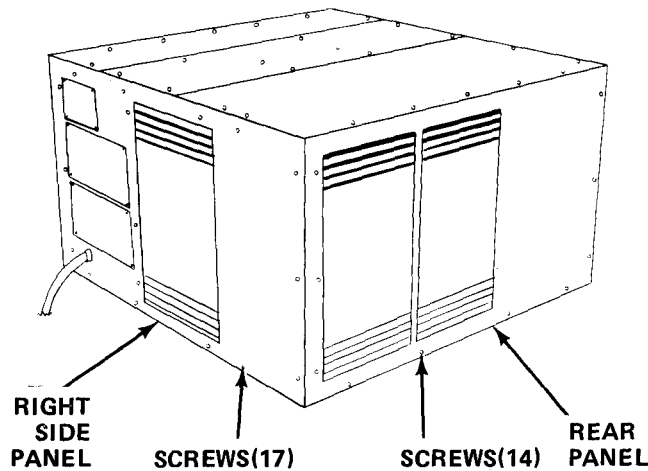

LOCATION/ITEM	REMARKS	ACTION
INSTALLATION		
TOP AND LEFT SIDE OF HOUSING		
22. Left Side Panel	<ul style="list-style-type: none"> a. Align holes in left side panel with holes in housing. b. Secure left side panel with seventeen (17) screws. 	
23. Top Rear Panel	<ul style="list-style-type: none"> a. Align holes in top rear panel with holes in housing. b. Secure top rear panel with nine (9) screws. 	
24. Top Front Panel	<ul style="list-style-type: none"> a. Align in top front panel with holes in housing. b. Secure top front panel with seven (7) screws. 	
25. Top Center Panel	<ul style="list-style-type: none"> a. Align holes in top center panel with holes in top front and top rear panels. b. Secure top center panel with ten (10) screws 	

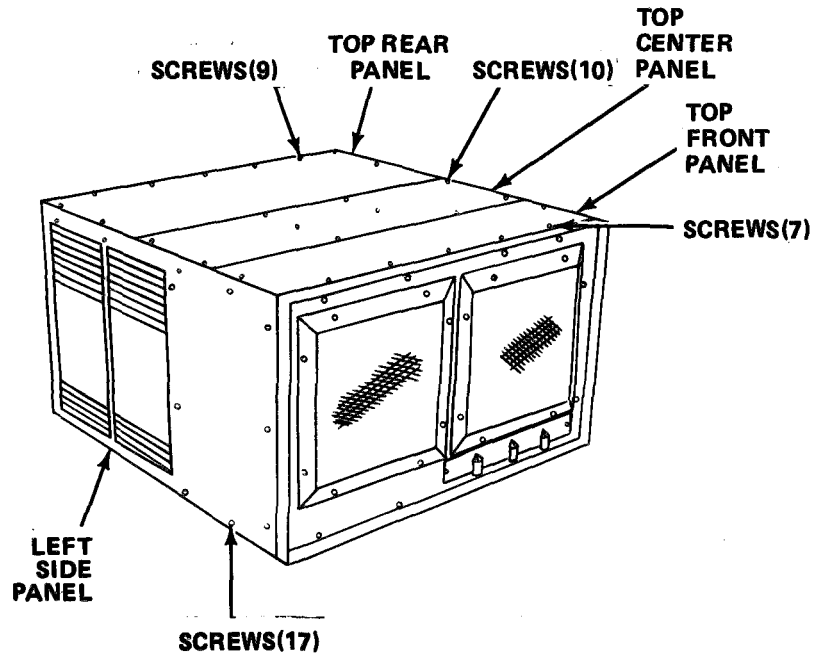

4-19. AIR FILTER

This task covers:

- a. Removal
- b. Inspection
- c. Service
- d. Installation

INITIAL SETUP

Material/Parts

- Air Filter Cover Screws (12)
- Dry Cleaning Solvent
- Filterkote or Oil

References
NONE

Troubleshooting Reference

AIR CONDITIONER, Malfunction 2, Step 2

Approximate Time Required (in minutes)

	10
Inspection and Service	10
Installation	10
TOTAL TIME	30

LOCATION/ITEM	REMARKS	ACTION
---------------	---------	--------

REMOVAL

BOTTOM OF HOUSING

- 1. Air Filter
 - a. Remove twelve (12) screws securing air filter cover to bottom of air conditioner.
 - b. Remove air filter cover and gasket.
 - c. Slide air filter down and out of air conditioner.

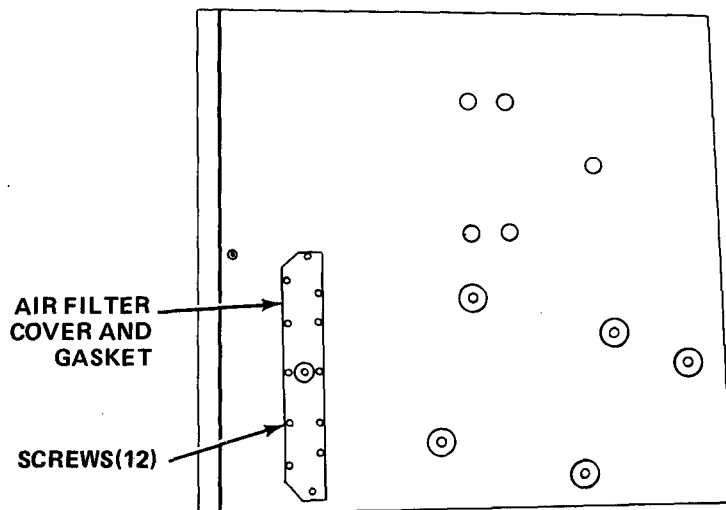

LOCATION/ITEM	REMARKS	ACTION
---------------	---------	--------

INSPECTION AND SERVICE

- | | | |
|----------------------------|--|--|
| 2. Air Filter Cover Gasket | | <ul style="list-style-type: none"> <i>a.</i> Inspect gasket for damage or deterioration. <i>b.</i> Replace gasket with rubber per specification ASTM D2000,2BG505F17L14. |
|----------------------------|--|--|

WARNING

Dry cleaning solvent P-D-680 or P-S-661, used to clean parts is potentially dangerous to personnel and property. Avoid contact and prolonged skin contact. Do not use near open flame or excessive heat. Flash point of solvent is 100° F (38°).

WARNING

Do not use compressed air for cleaning purposes except where reduced to less than 30 psi and then only with effective chip uamline and personal protective equipment

- | | | |
|---------------|--|--|
| 3. Air Filter | | <ul style="list-style-type: none"> <i>a.</i> Clean air with P-D-680 or P-S-661 dry cleaning solvent or warm soapy water. <i>b.</i> Dry air filter with low pressure compressed air. <i>c.</i> Inspect air filter for damaged or clogged condition. <i>d.</i> Replace air filter if damage is indicated. <i>e.</i> Inspect two (2) rubber pads on bottom of air filter for damaged condition. <i>f.</i> Replace pads with a 2-inch long piece rubber accordance D2000-2BG505F17L14. <i>g.</i> Secure with adhesive per specification <i>h.</i> Dip or spray-air filter with filterkote or oil per specification MIL-L-2104 Grade 20, 30 or <i>i.</i> Drain off excess oil before installation. |
|---------------|--|--|

BOTTOM OF HOUSING

- | | | |
|---------------|--|---|
| 4. Air Filter | | <ul style="list-style-type: none"> <i>a.</i> Slide air filter up into air conditioner. <i>b.</i> Install gasket and air filter cover. <i>c.</i> Secure air filter cover with twelve (12) screws. |
|---------------|--|---|

4-20. FAN MOTOR

This task covers:

- a. Removal
- b. Inspection

- c. Test
- d. Installation

INITIAL SETUP

Material/Parts

- Right Side Panel Screws (17)
- Top Center Panel Screws (10)
- Return Air Grill Screws (8)
- Air Diffuser Grill Screws (8)
- Control Panel Plate Screws (2)
- Front Panel Screws (14)
- Blower Intake Ring Screws (7)
- Fan Motor Capscrews (4)
- Fan Motor Self-Locking Nuts (4)
- Thermostat Switch Screws (2)

Referenes
None

Troubleshooting Reference

- FANS, Malfunction 1, Step 2
- COMPRESSOR, Malfunction 2, Step 1
- AIR OUTPUT, Malfunction 1, Step 4
- AIR OUTPUT, Malfunction 2, Step 4
- NOISE, Malfunction 1, Step 3

Approximate Time Required (in minutes)

Removal	30
Inspection and Testing	15
Repair	15
Installation	30
TOTAL TIME	90

LOCATION/ITEM	REMARKS	ACTION
---------------	---------	--------

REMOVAL

RIGHT SIDE AND TOP OF HOUSING

1. Right Side Panel

- a. Remove seventeen (17) screws securing right side panel.
- b. Remove right side panel.

2. Top Center Panel

- a. Remove ten (10) screws securing top center panel.
- b. Remove top center panel.

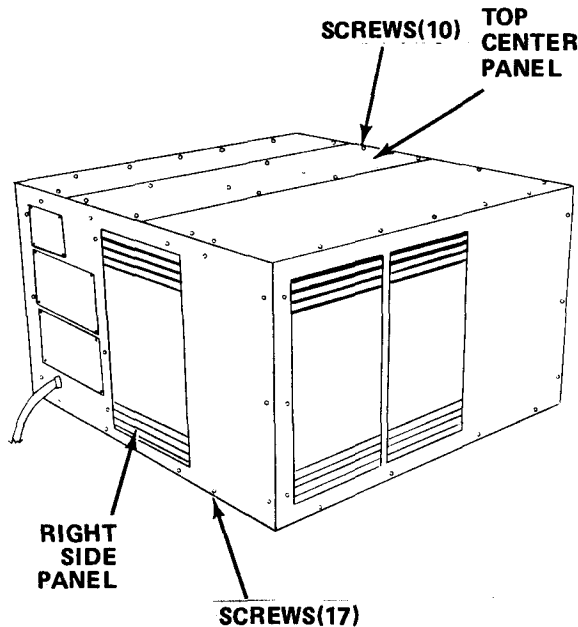

LOCATION/ITEM	REMARKS	ACTION
FRONT OF HOUSING		
3. Return Air Grill		<ul style="list-style-type: none"> a. Loosen mechanical screw post at rear of return air grill and remove wire b. Remove eight (8) screws securing return air c. Remove return air grill.
4. Air Diffuser Grill		<ul style="list-style-type: none"> a. Remove eight (8) screws securing air diffuser b. Remove air diffuser grill.
5. Control Panel Plate		<ul style="list-style-type: none"> a. Loosen setscrews and remove knobs from fresh air control, selector switch and thermostat switch. b. Remove two (2) screws securing control panel c. Remove control panel plate.
6. Front Panel		<ul style="list-style-type: none"> a. Remove two (2) screws securing thermostat switch to front panel. b. Remove fourteen (14) screws securing front c. Remove front panel.

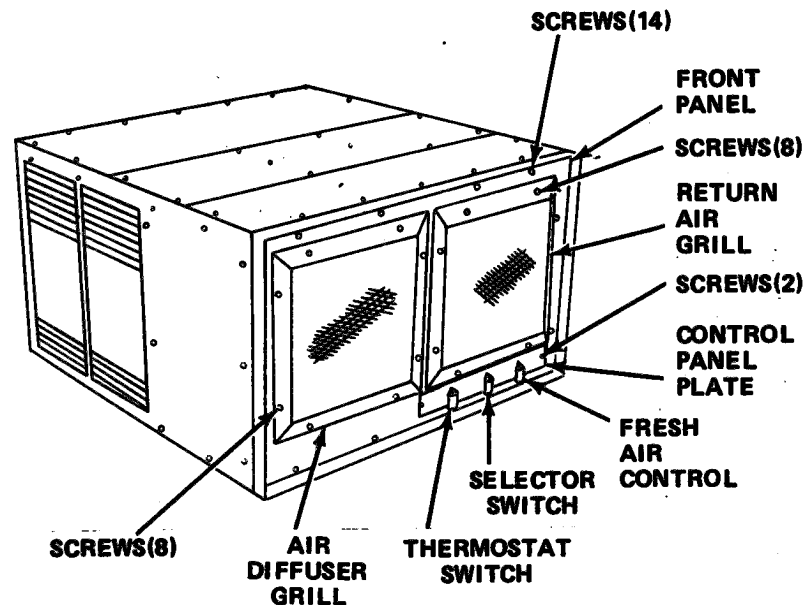

LOCATION/ITEM	REMARKS	ACTION
REMOVAL		
FRONT OF HOUSING		
7. Blower Intake Ring	<ul style="list-style-type: none"> a. Remove seven (7) screws securing blower intake ring. b. Remove blower intake ring. 	
8. Circulating Fan	<ul style="list-style-type: none"> a. Loosen setscrew in hub of circulating fan. b. Carefully remove circulating fan. 	

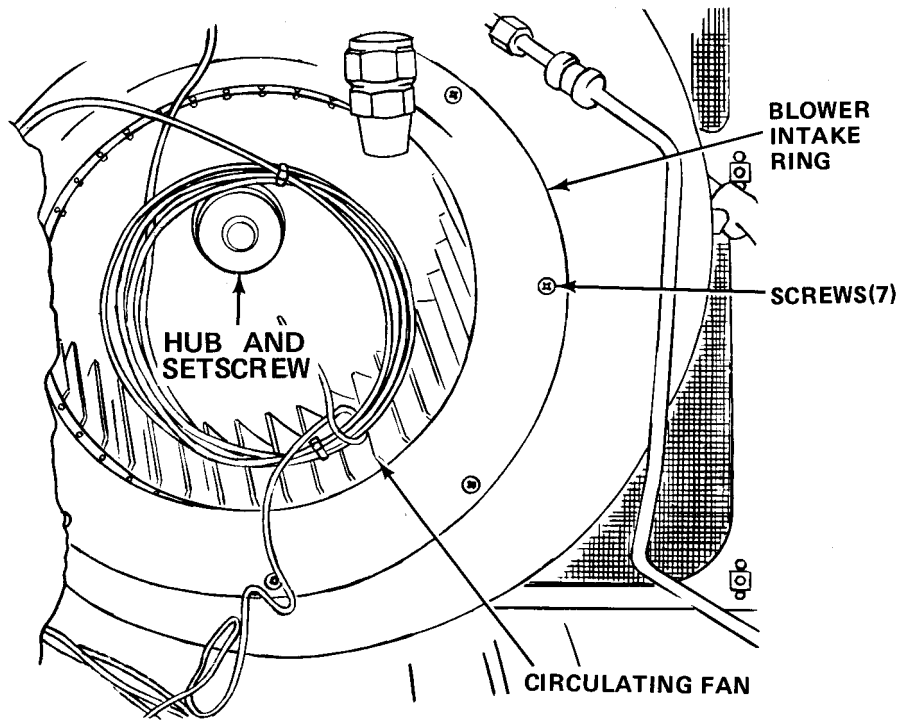

LOCATION/ITEM	REMARKS	ACTION
---------------	---------	--------

REMOVAL

RIGHT SIDE OF HOUSING

WARNING

Death or serious injury may occur if capacitor is not discharged prior to removal.

9. Fan Motor

- a. Remove upper four (4) capscrews and self-lockin nuts securing motor to motor mounting bracket.
- b. Slide motor back a against nat bulkhead.
- c. Loosen setscrew in hub of condenser fan.
- d. Discharge motor capacitor.
- e. Tag and disconnect electrical leads to motor capacitor.
- f. Tag and disconnect leads to fan motor.
- g. Remove fan motor from housing.

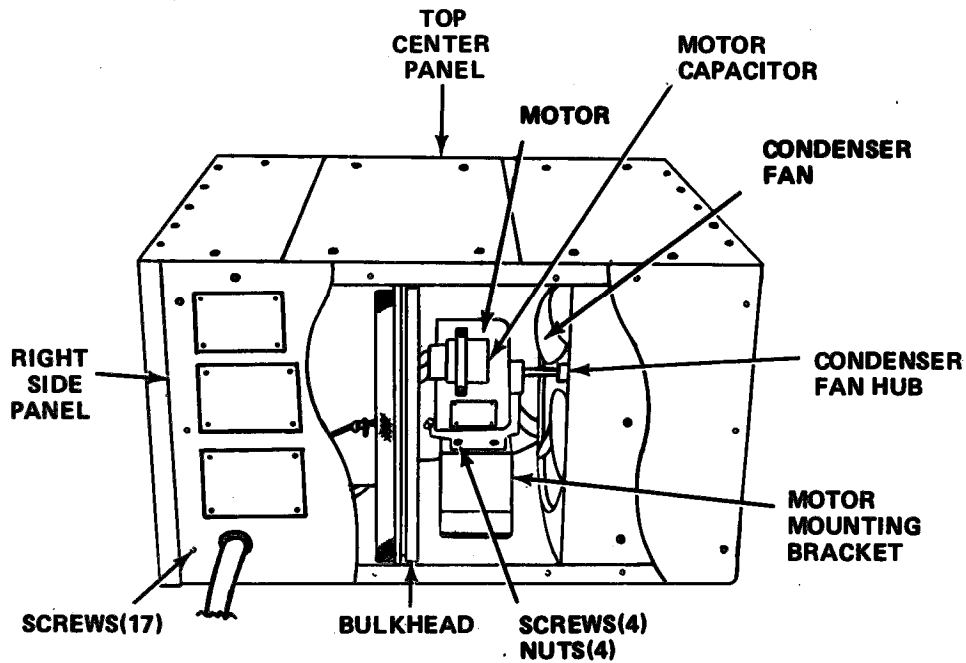

LOCATION/ITEM	REMARKS	ACTION
INSPECTION AND TESTING		
10. Fan Motor		<ul style="list-style-type: none"> a. Use a multimeter set on low ohms scale, check for continuity. b. Verify multimeter indicates low resistance across each pair of leads. c. Connect one multimeter lead to motor frame and second lead to each of the motor leads. d. Replace motor if there is NO resistance.
REPAIR		
11. Fan Motor		Repair electrical wirina as follows: <ul style="list-style-type: none"> (1) Remove insulation to expose 1/2 inch of bare wire on each side of break. (2) Twist the wire ends together and solder the splice. (3) Cover the splice with PVC electrical tape, making certain to cover all repaired areas.
INSTALLATION		
12. Fan Motor		<ul style="list-style-type: none"> a. Connect electrical leads to motor capacitor and remove tags. b. Connect electrical leads to fan motor and remove tags. c. Place fan motor on motor mounting bracket. d. Slide fan motor back against bulkhead.
INSTALLATION		
RIGHT SIDE OF HOUSING		
13. Condenser Fan		<ul style="list-style-type: none"> a. Install condenser fan on fan motor shaft. b. Tighten setscrew in condenser fan hub.
FRONT OF HOUSING		
14. Circulating Fan		<ul style="list-style-type: none"> a. Carefully install circulating fan on fan motor shaft. b. Tighten setscrew in circulating fan hub.
15. Blower Intake Ring		<ul style="list-style-type: none"> a. Align holes in blower intake ring with holes in circulatin fan housing. b. Secure blower intake ring with seven (7) screws.
16. Front Panel		<ul style="list-style-type: none"> a. Align holes in thermostat switch with holes in front panel. b. Secure thermostat switch to front panel with two (2) screws. c. Align holes in front panel with holes in housing. d. Secure front panel with fourteen (14) screws.

LOCATION/ITEM	REMARKS	ACTION
FRONT OF HOUSING		
17. Control Panel Plate	<ul style="list-style-type: none"> a. Align holes in control panel plate with holes in front panel. b. Secure control panel date with two (2) screws c. Install three (3) knobs on fresh air control, selector switch, and thermostat switch. 	
18. Air Diffuser Grill	<ul style="list-style-type: none"> a. Align holes in air diffuser grill with holes in front panel. b. Secure air diffuser grill with eight (8) straws. 	
19. Return Air Grill	<ul style="list-style-type: none"> a. Align holes in return air grill with holes in front panel. b. Secure return air grill with eight (8) screws. c. Install wire in mechanical screw post and tighten mechanical screw post. 	

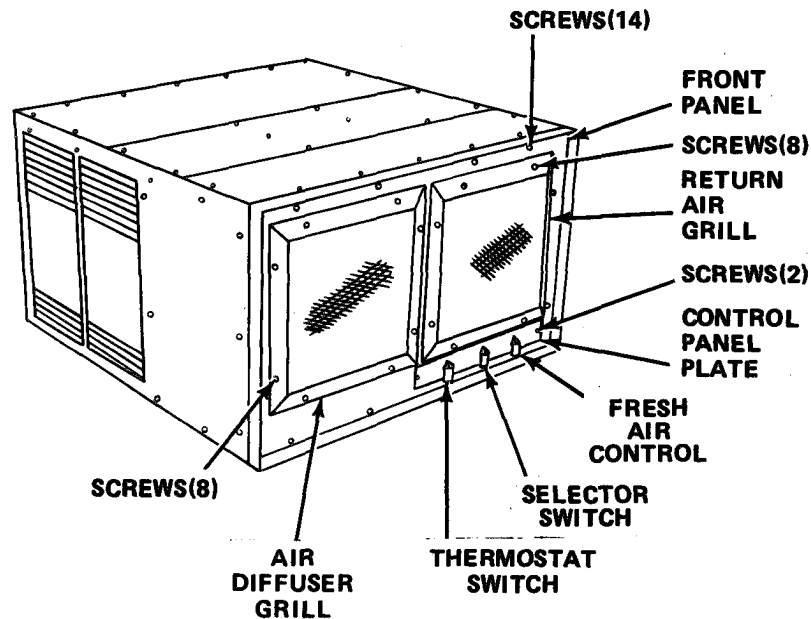

LOCATION/ITEM	REMARKS	ACTION
---------------	---------	--------

INSTALLATION

RIGHT SIDE AND TOP OF HOUSING

20. Top Center Panel

- a. Align holes in top center panel with holes in top rear and top front panels.
- b. Secure top center panel with ten (10) screws.

21. Right Side Panel

- a. Align holes in right side panel with holes in housing.
- b. Secure right side panel with seventeen (17) screws.

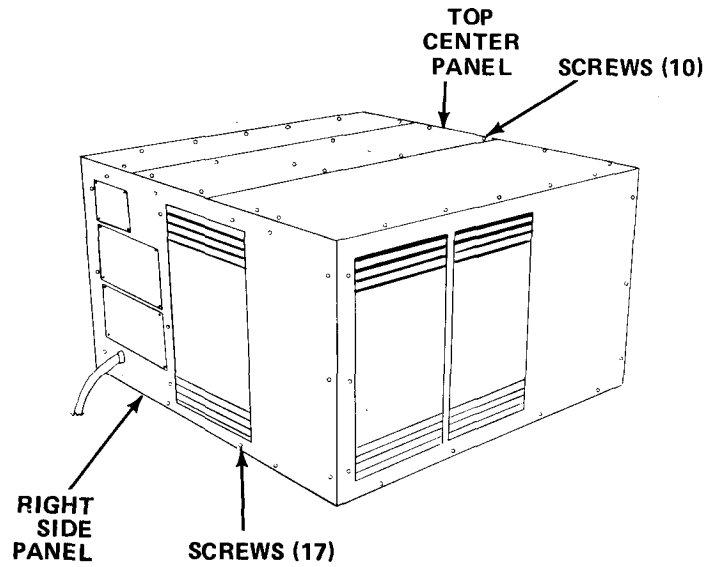

4-21. CONDENSER FAN

This task covers:

- a Removal
- b. Inspection
- c. Repair
- d Installation

INITIAL SETUP

MaterialPam

- Right Side Panel Screws (17)
- Top Center Panel Screws (10)
- Return Air Grill Screws (8)
- Air Diffuser Grill Screws (8)
- Control Panel Plate Screws (2)
- Front Panel Screws (14)
- Blower Intake Ring Screws (7)
- Fan Motor CapsCrews (4)
- Fan Motor Self-Locking Nuts 4)
- Thermostat Switch Screws (2)

References
None

Troubleshooting Reference

- FANS, Malfunction 1, Step 3
- AIR OUTPUT, Malfunction 2, Step 3
- NOISE, Malfunction 1, Step 2

Approximate Time Required (in minutes)

Removal	30
Inspection and Repair	20
Installation	30
TOTAL TIME	80

LOCATION/ITEM	REMARKS	ACTION
---------------	---------	--------

REMOVAL

RIGHT SIDE AND TOP OF HOUSING

- 1. Right Side Panel
 - a Remove seventeen (17) screws securing right side panel.
 - b. Remove right side panel,

- 2. Top Center Panel
 - a. Remove ten (10) screws securing top center
 - b. Remove top center panel.

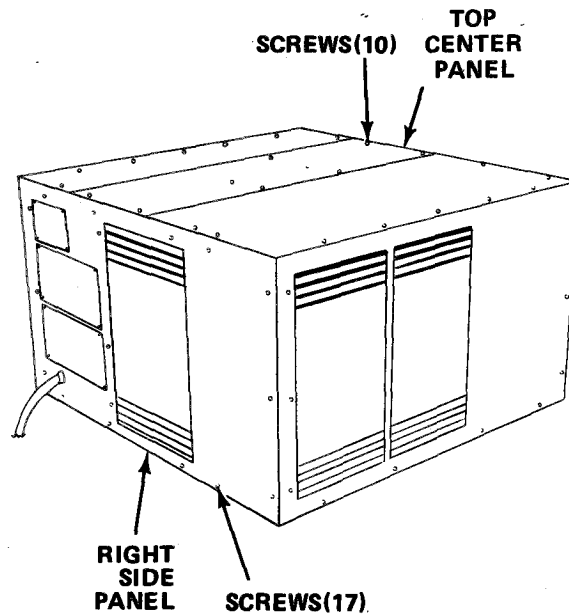

LOCATION/ITEM	REMARKS	ACTION
REMOVAL		
FRONT OF HOUSING		
3. Return Air Grill	<ul style="list-style-type: none"> a. Loosen mechanical screw post at rear of return grill and remove wire, b. Remove eight (8) screws securing return air grill. c. Remove return air grill. 	
4. Air Diffuser Grill	<ul style="list-style-type: none"> a. Remove eight (8) screws securing air diffuser grill. b. Remove air diffuser grill. 	
5. Control Panel Plate	<ul style="list-style-type: none"> a. Loosen setscrews and remove knobs from fresh air control, selector switch and thermostat switch. b. Remove two (2) screws securing control panel plate. c. Remove control panel plate. 	
6. Front Panel	<ul style="list-style-type: none"> a. Remove two (2) screws securing thermostat switch to front panel. b. Remove fourteen (14) screws securing front panel. c. Remove front panel. 	

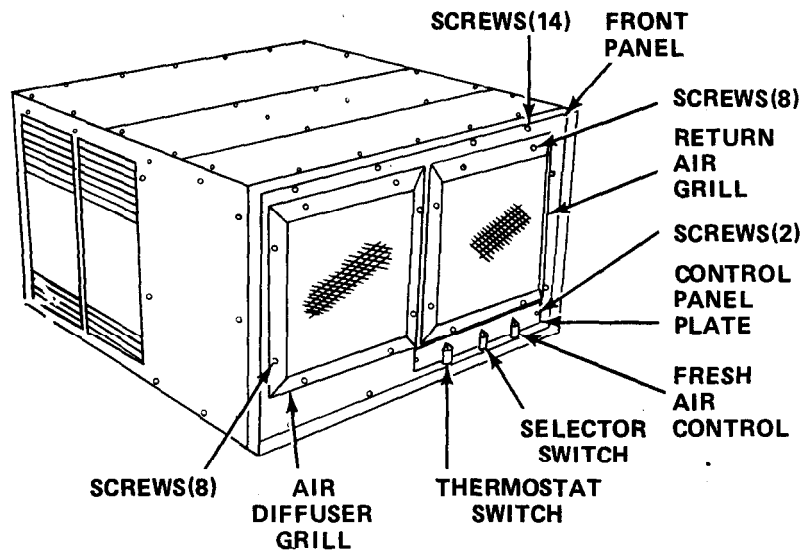

LOCATION/ITEM	REMARKS	ACTION
REMOVAL		
FRONT OF HOUSING		
7. Blower Intake Ring	<ul style="list-style-type: none"> 8. Remove seven (7) screws securing blower intake ring. b. Remove blower intake ring. 	
8. Circulating Fan	<ul style="list-style-type: none"> a. Loosen setscrew in hub of circulating fan. b. Carefully remove circulating fan. 	

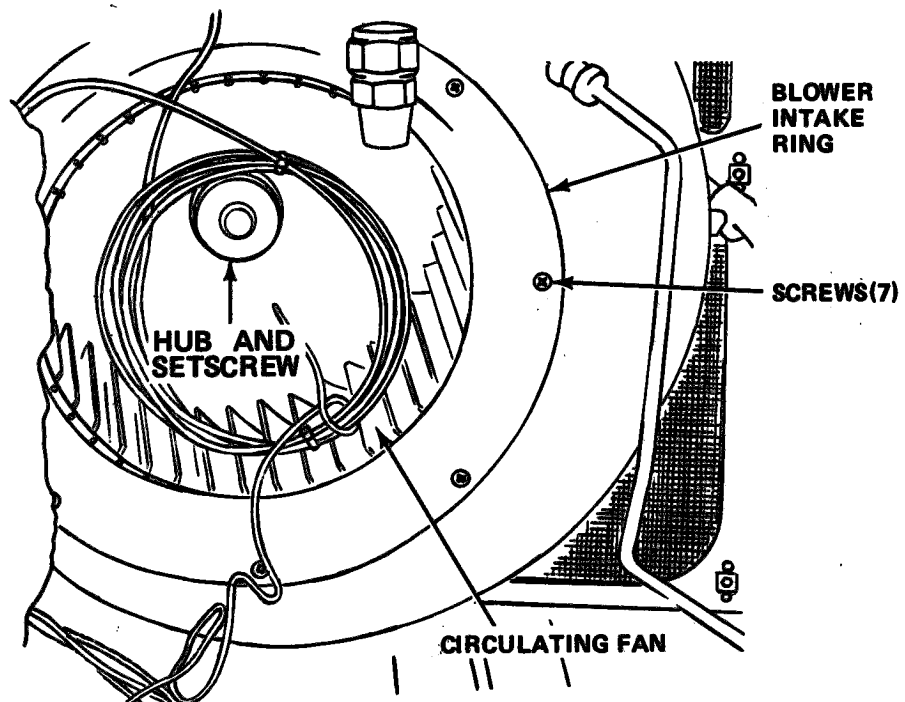

REMOVAL

RIGHT SIDE OF HOUSING

9. Condenser Fan	<ul style="list-style-type: none"> a. Remove upper four (4) capscrews and self-locking nuts securing fan motor to motor mounting racket. b. Slide fan motor back against bulkhead. c. Loosen setscrew in hub of condenser fan. d. Remove condenser fan.
------------------	---

LOCATION/ITEM	REMARKS	ACTION
---------------	---------	--------

INSPECTION AND REPAIR

10. Condenser Fan

- a. Inspect condenser fan, hub and setscrew for indication of excessive wear or damage.
- b. Replace condenser fan if damage to hub or condenser fan is indicated.
- c. Replace setscrew with a 1/4-28UNF-3A x .312 inch long setscrew if damage is indicated.

INSTALLATION

11. Condenser Fan

- a. Install condenser fan on fan motor shaft
- b. Tighten setscrew in condenser fan hub.
- c. Slide fan motor back into place on motor mounting bracket.
- d. Secure fan motor to motor mounting bracket with four (4) capscrews and self-locking nuts.

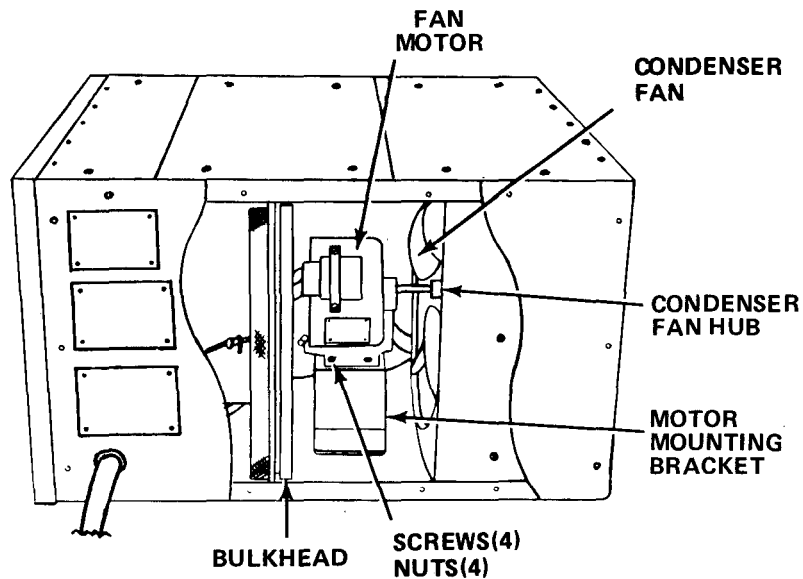

LOCATION/ITEM	REMARKS	ACTION
---------------	---------	--------

INSTALLATION

FRONT OF HOUSING

12. Circulating Fan

- a Carefully install circulating fan on fan motor shaft.
- b. Tighten setscrew in circulating fan hub,

13. Blower Intake Ring

- a Align holes in blower intake ring with holes in circulating fan housing.
- b. Secure blower intake ring with seven (7) screws,

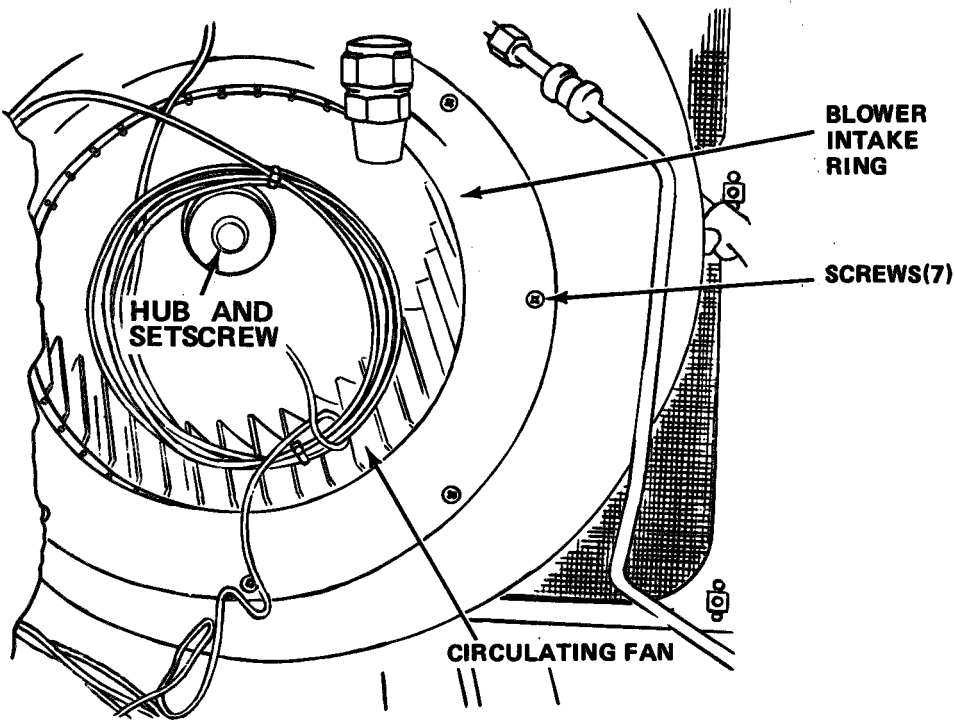

LOCATION/ITEM	REMARKS	ACTION
INSTALLATION		
FRONT OF HOUSING		
14. Front Panel		<ol style="list-style-type: none"> Align holes in thermostat switch with holes in front panel. Secure thermostat switch to front panel with two (2) screws. Align holes in front panel with holes in housing. Secure front panel with fourteen (14) screws,
15. Control Panel Plate		<ol style="list-style-type: none"> Align holes in control panel plate with holes in front panel, Secure control panel plate with two (2) screws. Install three (3) knobs on fresh air control, selector switch and thermostat switch.
16. Air Diffuser Grill		<ol style="list-style-type: none"> Align holes in air diffuser grill with holes in front panel. Secure air diffuser grill with eight (8) screws
17. Return Air Grill		<ol style="list-style-type: none"> Align holes in return air grill with holes in front panel. Secure return air grill with eight (8) screws, Install wire in mechanical screw post and tighten mechanical screw post.

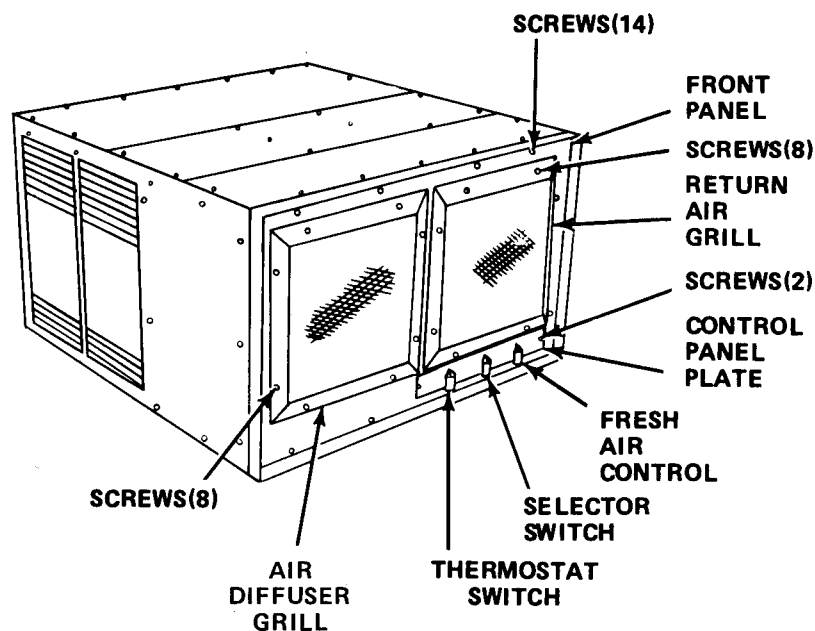

LOCATION/ITEM	REMARKS	ACTION
---------------	---------	--------

INSTALLATION

RIGHT SIDE AND TOP OF HOUSING

- | | |
|----------------------|---|
| 18. Top Center Panel | <ul style="list-style-type: none"> a. Align holes in top center panel with holes in top front and top rear panels. b. Secure top center panel with ten (10) screws. |
| 19. Right Side Panel | <ul style="list-style-type: none"> a. Align holes in right side panel with holes in housing. b. Secure right side panel with seventeen (17) screws. |

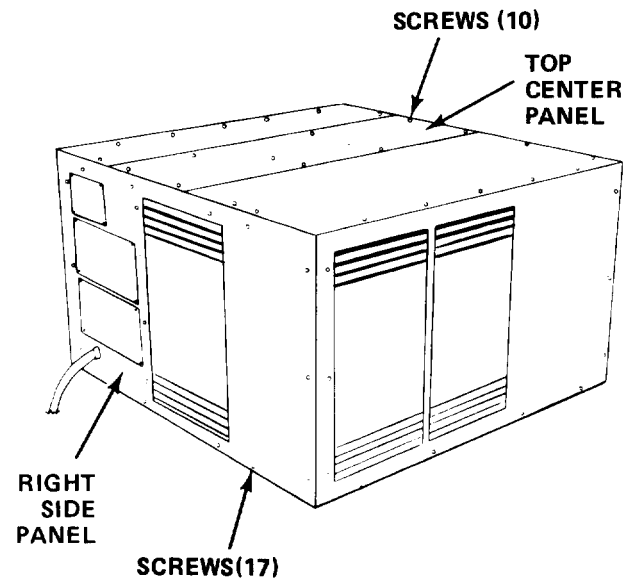

4-22. CIRCULATING FAN

This task covers:

- a. Removal
- b. Inspection
- c. Repair
- d. Installation

INITIAL SETUP

Material/Parts

- Right Side Panel Screws (17)
- Top Center Panel Screws (10)
- Return Air Grill Screws (8)
- Air Diffuser Grill Screws (8)
- Control Panel Plate Screws (8)
- Front Panel Screws (14)
- Blower Intake Ring Screws (7)
- Fan Motor Capscrews (4)
- Fan Motor Self-Locking Nuts (4)
- Thermostat Switch Screws (2)

References
None

Troubleshooting Reference

- AIR CONDITIONER, Malfunction 2, Step 6
- FANS, Malfunction 1, Step 3
- AIR OUTPUT, Malfunction 1, Step 3
- NOISE, Malfunction 1, Step 1

Approximate Time Required (in minutes)

Removal	30
Inspection and Repair	20
Installation	30
TOTAL TIME	80

LOCATION/ITEM	REMARKS	ACTION
---------------	---------	--------

REMOVAL

RIGHT SIDE OF HOUSING

1. Right Side Panel
 - a. Remove seventeen (17) screws securing right side panel.
 - b. Remove right side panel.

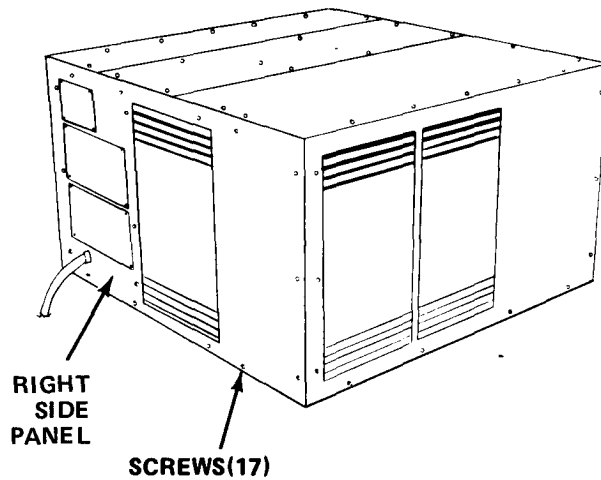

LOCATION/ITEM	REMARKS	ACTION
REMOVAL		
FRONT OF HOUSING		
2. Return Air Grill		a. Loosen mechanical screw post at rear of return air grill and remove wire. b. Remove eight (8) screws securing return air grill. c. Remove return air grill.
3. Air Diffuser Grill		a. Remove eight (8) screws securing air diffuser grill. b. Remove air diffuser grill.
4. Control Panel Plate		a. Loosen setscrews and remove knobs from fresh air control, selector switch and thermostat switch. b. Remove two (2) screws securing control panel plate. c. Remove control panel plate.
5. Front Panel		a. Remove two (2) screws securing thermostat switch to front panel. b. Remove fourteen (14) screws securing front panel. c. Remove front panel.

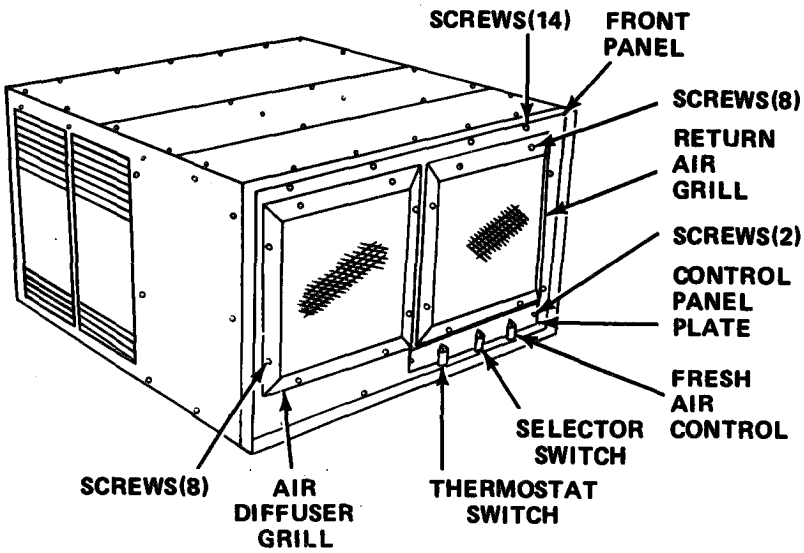

LOCATION/ITEM	REMARKS	ACTION
REMOVAL		
FRONT OF HOUSING		
6. Blower Intake Ring		<ul style="list-style-type: none"> a. Remove seven (7) screws securing blower intake ring. b. Remove blower intake ring.
7. Circulating Fan		<ul style="list-style-type: none"> a. Loosen setscrew in hub of circulating fan. b. Carefully remove circulating fan.
INSPECTION AND REPAIR		
8. Circulating Fan		<ul style="list-style-type: none"> a. Inspect circulating fan, hub and setscrew for indication of excessive wear or damage. b. Replace circulating fan if damage to hub or circulating fan is indicated. c. Replace setscrew with a 1/4-28UNF-3A x .312 inch long setscrew if damage is indicated.
INSTALLATION		
9. Circulating Fan		<ul style="list-style-type: none"> a. Carefully install circulating fan on fan motor b. Tighten setscrew in circulating fan hub.
10. Blower Intake Ring		<ul style="list-style-type: none"> a. Align holes in blower intake ring with holes in circulating fan housing. b. Secure blower intake ring with seven (7) screws.

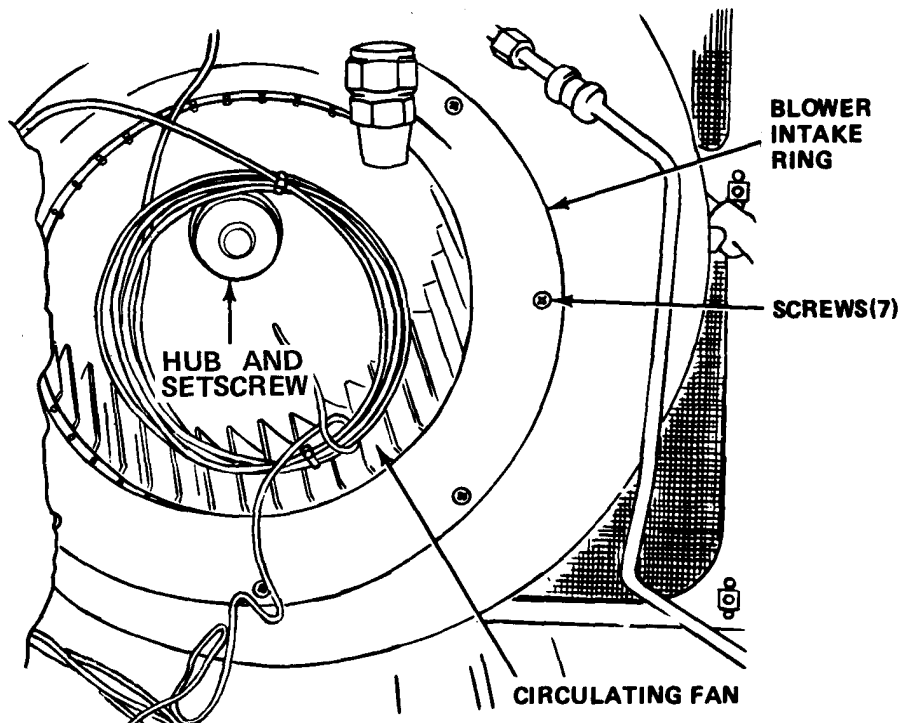

LOCATION/ITEM	REMARKS	ACTION
INSTALLATION		
FRONT OF HOUSING		
11. Front Panel	<ul style="list-style-type: none"> a. Align holes in thermostat switch with holes in front panel. b. Secure thermostat switch to front panel with two (2) screws. c. Align holes in front panel with holes in housing. d. Secure front panel with fourteen (14) screws. 	
12. Control Panel Plate	<ul style="list-style-type: none"> a. Align holes in control panel plate with holes in front panel. b. Secure control panel plate with two (2) screws. c. Install three (3) knobs on fresh air control, selector switch and thermostat switch. 	
13. Air Diffuser Grill	<ul style="list-style-type: none"> a. Align holes in air diffuser grill with holes in front panel. b. Secure air diffuser grill with eight (8) screws 	
14. Return Air Grill	<ul style="list-style-type: none"> a. Align holes in return air grill with holes in front panel. b. Secure return air grill with eight (8) screws. c. Install wire in mechanical screw post and tighten mechanical screw post. 	

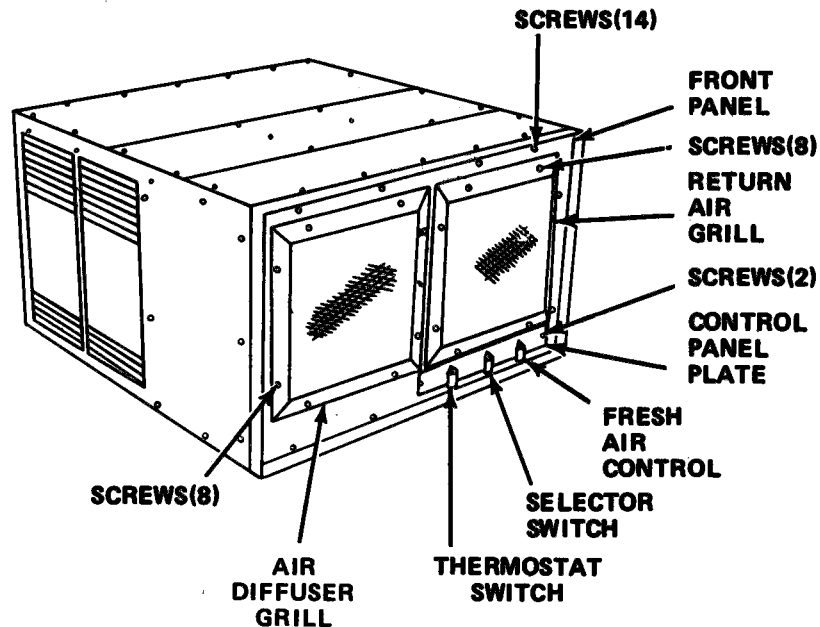

LOCATION/ITEM	REMARKS	ACTION
---------------	---------	--------

INSTALLATION

RIGHT SIDE OF HOUSING

15. Right Side Panel

- a. Align holes in right side panel with holes in housing.
- b. Secure right side panel with seventeen (17) screws.

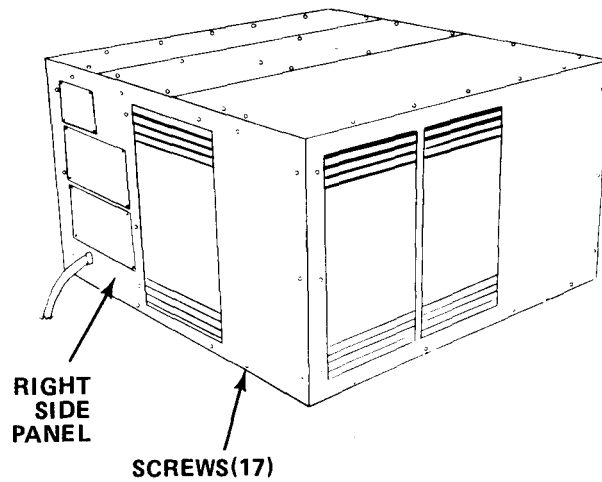

4-23. SELECTOR SWITCH

This task covers:

- a. Removal
- b. Test
- c. Installation

INITIAL SETUP

Material/Parts

- Right Side Panel Screws (17)
- Control Panel Plate Screws (2)
- Selector Switch Screws (2)
- Return Air Grill Screws (8)

References

- Appendix F, Wiring Diagram

Troubleshooting Reference

AIR CONDITIONER, Malfunction 1, Step 5

Approximate Time Required (in minutes)

Removal	10
Test	10
Installation	10
TOTAL TIME	30

LOCATION/ITEM	REMARKS	ACTION
---------------	---------	--------

RIGHT SIDE OF HOUSING

- 1. Right Side Panel
 - a. Remove seventeen (17) screws securing right side panel.
 - b. Remove right side panel.

NOTE

The selector switch may be tested while installed in the air conditional. To gain access to the selector switch, remove the right side panel.

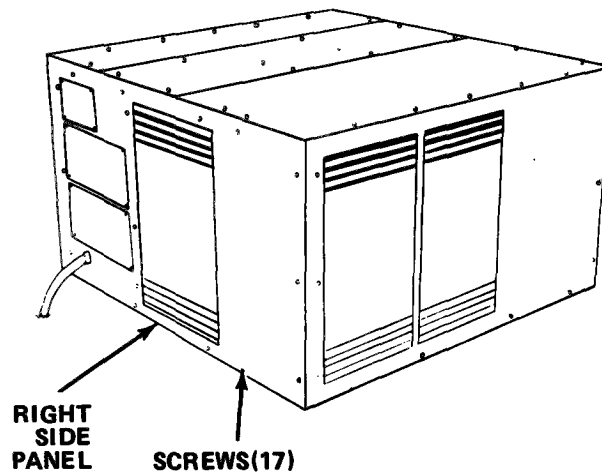

LOCATION/ITEM	REMARKS	ACTION
REMOVAL		
FRONT OF HOUSING		
2. Return Air Grill	<ul style="list-style-type: none"> a. Remove eight (8) screws securing return air grill to front panel. b. Partially remove return air grill from front panel. 	
3. Selector Switch	<ul style="list-style-type: none"> a. Loosen setscrews and remove three (3) knobs. b. Remove two (2) screws securing control panel plate to front panel. c. Remove control panel plate. d. Tag and disconnect electrical leads from selector switch. e. Remove two (2) screws securing selector switch to front panel. f. Remove selector switch. 	
TESTING		
4. Selector Switch	<ul style="list-style-type: none"> a. Tag and disconnect electrical leads from selector switch. b. Using an ohmmeter, measure resistance between the related contacts at each switch setting as follows (see Wiring Diagram, Appendix F): <ul style="list-style-type: none"> (1) With selector switch in the OFF position, resistance should be high. (2) With selector switch in the FAN position, high resistance should be indicated at the compressor terminal and low resistance should be indicated at the fan terminal. (3) With selector switch in the COOL position, low resistance should be indicated. c. Replace selector switch if testing indicates that it is defective. 	
INSTALLATION		
FRONT OF HOUSING		
5. Selector Switch	<ul style="list-style-type: none"> a. Connect electrical leads to selector switch and remove tags. b. Align holes in selector switch with holes in front panel. c. Secure selector switch with two (2) screws. d. Align holes in control panel plate with holes in front panel. e. Secure control panel plate with two (2) screws. f. Install three (3) knobs and tighten setscrews. 	

LOCATION/ITEM	REMARKS	ACTION
---------------	---------	--------

INSTALLATION

FRONT OF HOUSING

6. Return Air Grill

- a. Align holes in return air grill with holes in front panel.
- b. Secure return air grill to front panel with eight (8) screws.
- a. Connect electrical leads to selector switch and remove tags.
- b. Align holes in selector switch with holes in front panel.
- c. Secure selector switch with two (2) screws.
- d. Align holes in control panel plate with holes in front panel.
- e. Secure control panel plate with two (2) screws.
- f. Install three (3) knobs and tighten setscrews.

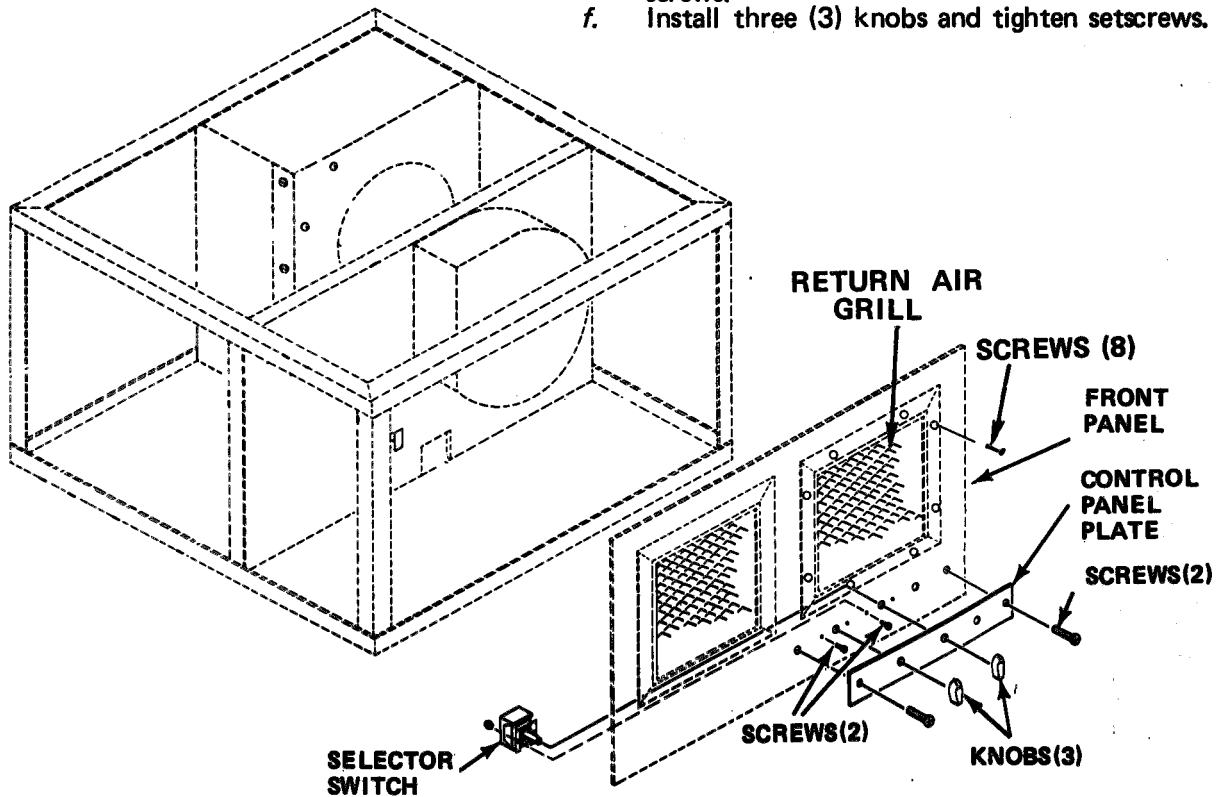

LOCATION/ITEM	REMARKS	ACTION
---------------	---------	--------

INSTALLATION

RIGHT SIDE OF HOUSING

7. Right Side Panel

- a. Align holes in right side panel with holes in housing.
- b. Secure right side panel with seventeen (17) screws.

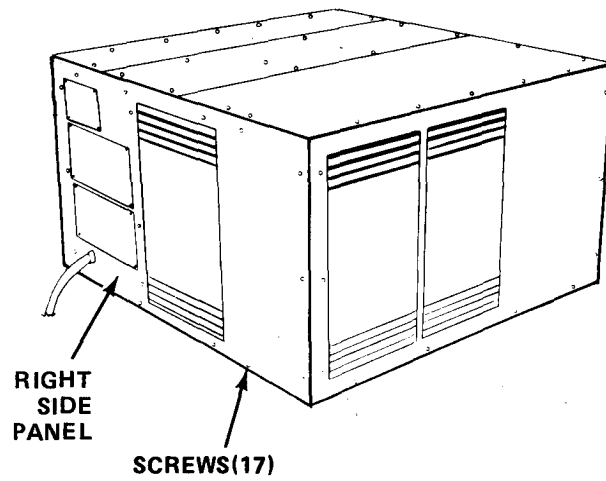

4-24. THERMOSTAT SWITCH

This task covers:

- a. Removal
- b. Test

- c. Installation

INITIAL SETUP

Material/Parts

- Right Side Panel Screws (17)
- Control Panel Plate Screws (2)
- Thermostat Switch Screws (2)
- Return Air Grill Screws (8)

References

Appendix F, Wiring Diagram

Troubleshooting Reference

AIR OUTPUT, Malfunction 2, Step 2

Approximate Time Required (in minutes)

Removal	10
Test	10
Installation	10
TOTAL TIME	30

LOCATION/ITEM	REMARKS	ACTION
---------------	---------	--------

- 1. Right Side Panel

- a. Remove seventeen (17) screws securing right side panel.
- b. Remove right side panel.

NOTE

The thermostat switch may be tested while installed in the air conditioner. To gain access to the selector switch, remove the right side panel.

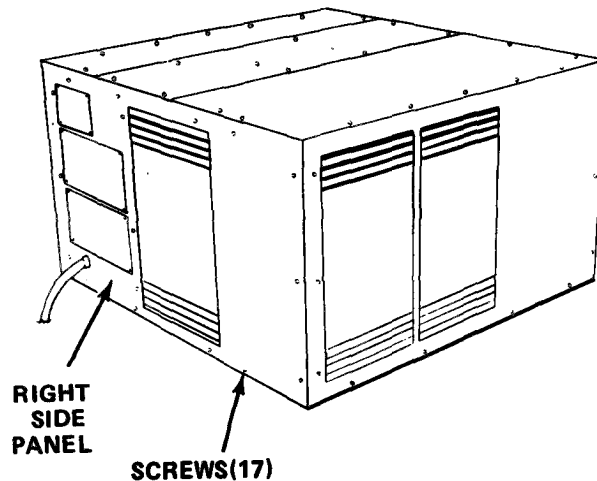

LOCATION/ITEM	REMARKS	ACTION
REMOVAL		
FRONT OF HOUSING		
2. Return Air Grill	<ul style="list-style-type: none"> a. Remove eight (8) screws securing return air grill to front panel. b. Partially remove return air grill from front panel. 	
CAUTION		
Carefully unwrap thermostat switch sensing bulb from expansion valve sensing line. Use care to prevent damage to sensing bulb.		
3. Thermostat Switch	<ul style="list-style-type: none"> a. Loosen setscrews and remove three (3) knobs. b. Remove two (2) screws securing control panel plate to front panel. c. Remove control panel plate. d. Tag and disconnect electrical leads from thermostat switch. e. Remove two (2) screws securing thermostat switch to front panel. f. Unwrap thermostat switch sensing bulb and remove thermostat switch. 	
TESTING		
4. Thermostat Switch	<ul style="list-style-type: none"> a. Tag and disconnect electrical leads from thermostat switch. b. With the thermostat switch set below room temperature use an ohmmeter and measure for Continuity across the thermostat switch terminals (see Wiring Diagram, Appendix F). c. Verify that the resistance indicated is zero ohms. d. Move thermostat switch setting to a position above room temperature. e. Verify that the resistance is infinity. f. Replace thermostat switch if testing indicates that it is defective. 	
INSTALLATION		
FRONT OF HOUSING		
5. Thermostat Switch	<ul style="list-style-type: none"> a. Connect electrical leads to thermostat switch and remove tags. b. Align holes in thermostat switch with holes in front panel. c. Secure thermostat switch with two (2) screws. d. Carefully wrap thermostat switch sensing bulb around expansion valve sensing line. e. Align holes in control panel plate with holes in front panel. f. Secure control panel plate with two (2) screws. g. Install three (3) knobs and tighten setscrews. 	

LOCATION/ITEM	REMARKS	ACTION
---------------	---------	--------

INSTALLATION

FRONT OF HOUSING

6. Return Air Grill

- a.* Align holes in return air grill with holes in front panel.
- b.* Secure return air grill to front panel with eight (8) screws.
- a.* Connect electrical leads to thermostat switch and remove tags.
- b.* Align holes in thermostat switch with holes in front panel.
- c.* Secure thermostat switch with two (2) screws.
- d.* Align holes in control panel plate with holes in front panel.
- e.* Secure control panel plate with two (2) screws.
Install three (3) knobs and tighten setscrews.

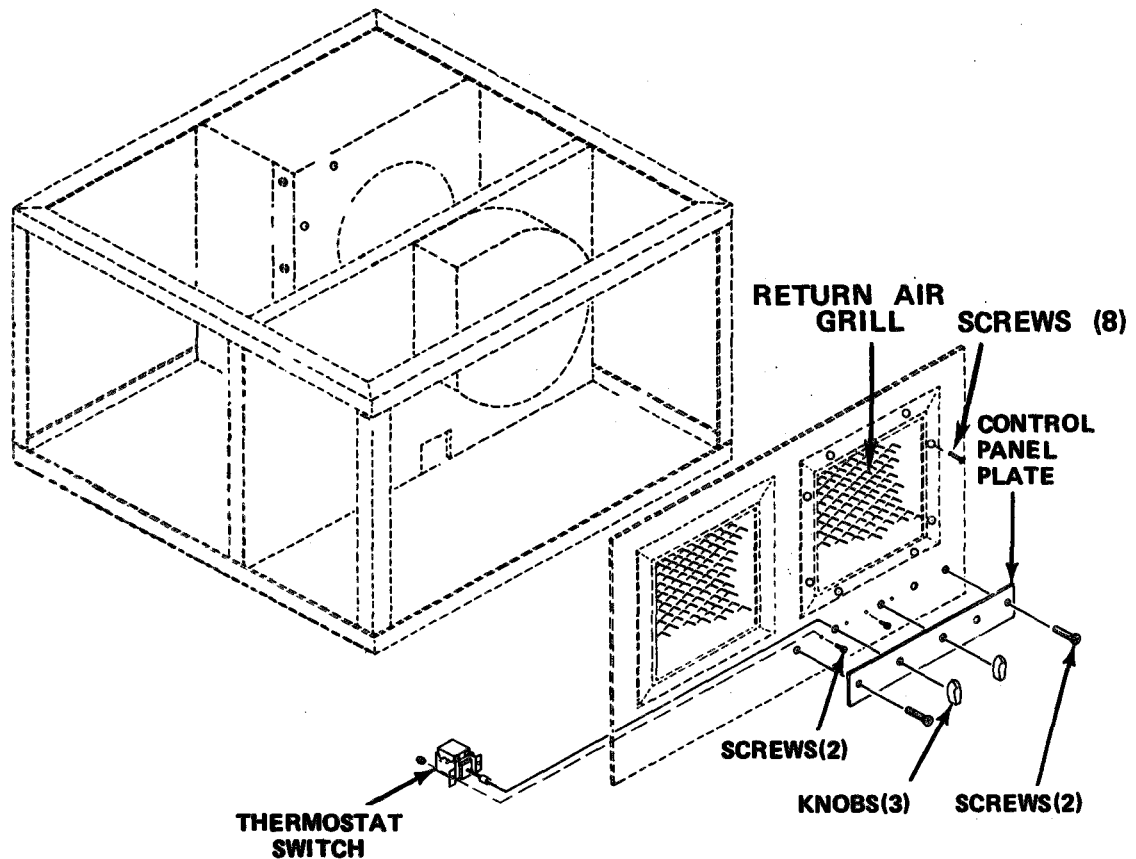

LOCATION/ITEM	REMARKS	ACTION
---------------	---------	--------

INSTALLATION

RIGHT SIDE OF HOUSING

7. Right Side Panel

- a. Align holes in right side panel with holes in housing.
- b. Secure right side panel with seventeen (17) screws.

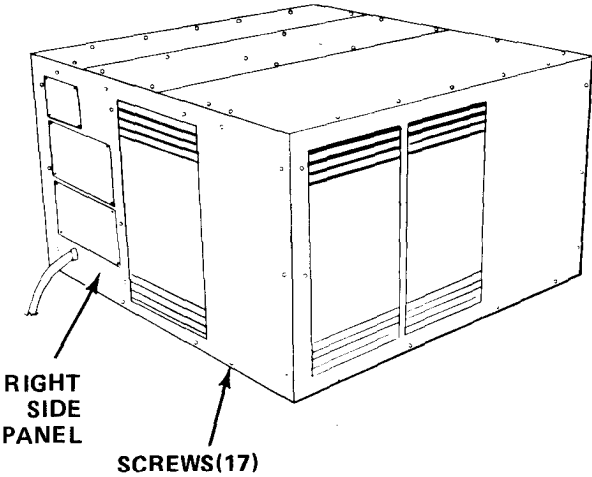

4-25. MOTOR CAPACITOR

This task covers:

- a. Removal
- b. Test
- c. Installation

INITIAL SETUP

Material/Parts

- Right Side Panel Screws (17)
- Capacitor Bracket Screws (2)

Troubleshooting Reference

FANS, Malfunction 1, Step 4

Approximate Time Required (in minutes)

Removal	10
Testing	5
Installation	10
TOTAL TIME	25

References
None

LOCATION/ITEM	REMARKS	ACTION
---------------	---------	--------

REMOVAL

RIGHT SIDE OF HOUSING

- 1. Right Side Panel
 - a. Remove seventeen (17) screws securing right side panel.
 - b. Remove right side panel.

WARNING

Death or serious injury may occur if capacitor is not discharged prior to removal.

- 2. Motor Capacitor
 - a. Discharge motor capacitor.
 - b. Slide rubber boot on motor capacitor enough to gain access to terminals.
 - c. Tag and disconnect electrical leads from motor capacitor.
 - d. Remove two (2) screws securing capacitor bracket to motor.
 - e. Remove capacitor bracket and motor capacitor.

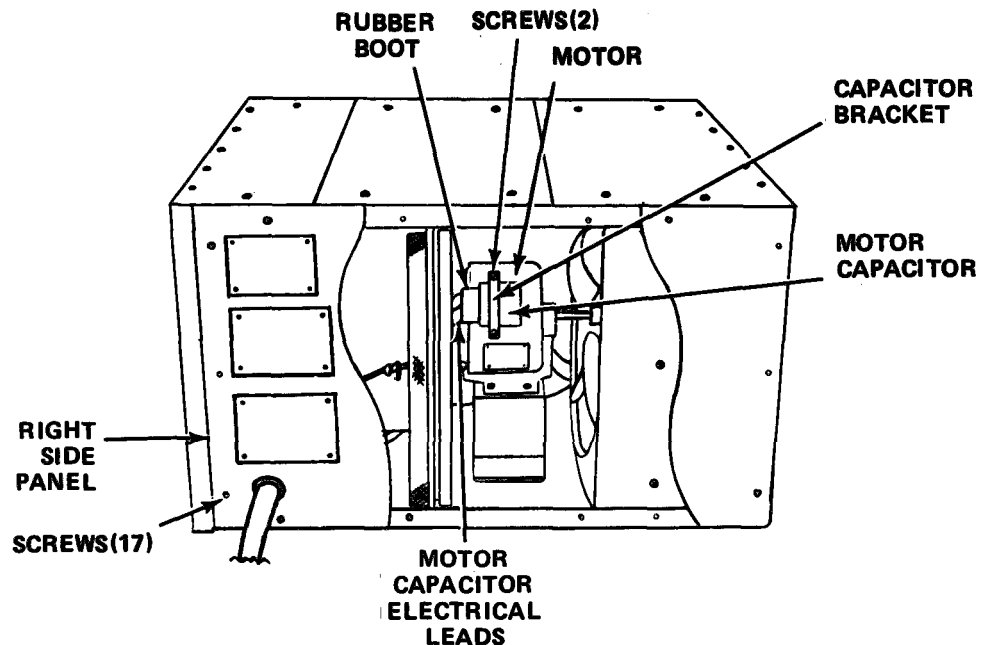

LOCATION/ITEM	REMARKS	ACTION
TESTING		
RIGHT SIDE OF HOUSING		
3. Motor Capacitor		<ul style="list-style-type: none"> a. Test motor capacitor with a suitable capacitor tester for continuity, leakage short, and capacitance, b. The motor capacitor is rated at 3 microfarads, 370 volts. c. Replace motor capacitor if testing indicates that it is defective.
INSTALLATION		
4. Motor Capacitor		<ul style="list-style-type: none"> a. Install motor capacitor in capacitor bracket. b. Align holes in capacitor bracket and motor. c. Secure capacitor bracket with two (2) screws. d. Connect electrical leads to motor capacitor and remove tags. e. Cover electrical leads with rubber boot.
5. Right Side Panel		<ul style="list-style-type: none"> a. Align holes in right side panel with holes in b. Secure right side panel with seventeen (17) screws.

4-26. START CAPACITOR

This task covers:

- a. Removal
- b. Test
- c. Installation

INITIAL SETUP

Material/Parts
Left Side Panel Screws (17)

Troubleshooting Reference
None

Approximate Time Required (in minutes)

Removal	10
Testing	10
Installation	10
TOTAL TIME	30

References
None

LOCATION/ITEM	REMARKS	ACTION
---------------	---------	--------

REMOVAL

LEFT SIDE OF HOUSING

- | | |
|---------------------------|--|
| <p>1. Left Side Panel</p> | <ul style="list-style-type: none"> a. Remove seventeen (17) screws securing left side panel to housing. b. Remove left side panel. |
|---------------------------|--|

Death or serious injury may occur if capacitor is not discharged prior to removal.

- | | |
|---------------------------|---|
| <p>2. Start Capacitor</p> | <ul style="list-style-type: none"> a. Pull start capacitor from bracket. b. Remove cap from start capacitor. c. Discharge start capacitor. d. Tag and disconnect electrical leads from start capacitor. |
|---------------------------|---|

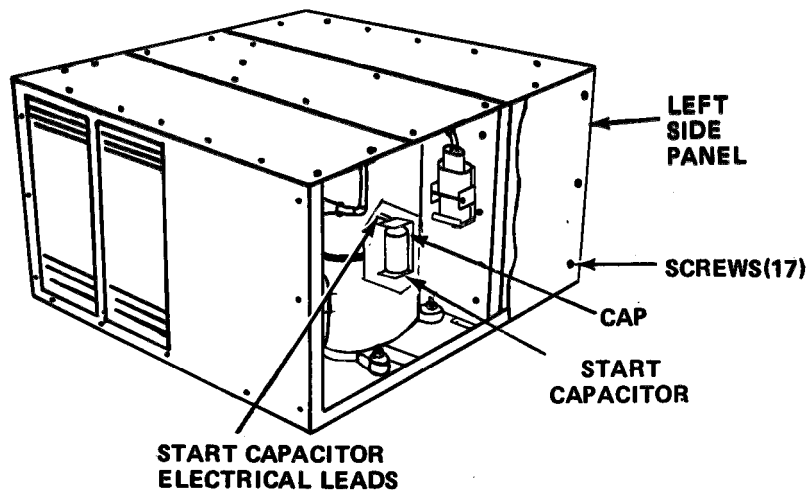

LOCATION/ITEM	REMARKS	ACTION
TESTING		
LEFT SIDE OF HOUSING		
3. Start Capacitor	<ul style="list-style-type: none"> a. Test start capacitor with a suitable capacitor tester for continuity, leakage short, and capacitance. b. The start capacitor is rated at 500 microfarads, 125 volts AC. c. Replace start capacitor if testing indicates that it is defective. 	
INSTALLATION		
4. Start Capacitor	<ul style="list-style-type: none"> a. Connect electrical leads to start capacitor and remove tags. b. Cover electrical leads with cap. c. Install start capacitor in bracket. 	
5. Left Side Panel	<ul style="list-style-type: none"> a. Align holes in left side panel with holes in housing. b. Secure left side panel with seventeen (17) screws. 	

4-27. RUN CAPACITOR

This task covers:

- a. Removal
- b. Test
- c. Installation

INITIAL SETUP

Material/Parts
 Left Side Panel Screws (17)

Troubleshooting Reference
 None

Approximate Time Required (in minutes)

Removal	10
Testing	10
Installation	10
TOTAL TIME	30

References
 None

LOCATION/ITEM	REMARKS	ACTION
---------------	---------	--------

LEFT SIDE OF HOUSING

- 1. Left Side Panel
 - a. Remove seventeen (17) screws securing left side panel to housing.
 - b. Remove left side panel.

WARNING

Death or serious injury may occur if capacitor is not discharged prior to removal.

- 2. Run Capacitor
 - a. Discharge run capacitor.
 - b. Remove cap from run capacitor.
 - c. Tag and disconnect electrical leads from run capacitor.
 - d. Loosen capacitor bracket screw.
 - e. Remove run capacitor from capacitor bracket.

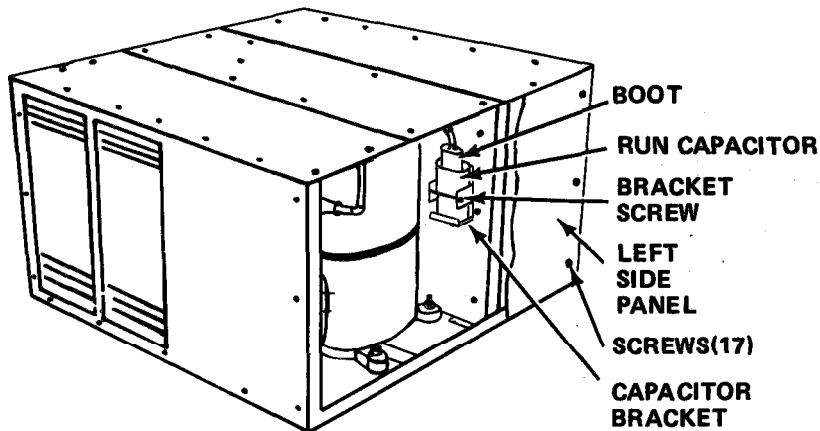

LOCATION/ITEM	REMARKS	ACTION
TESTING		
LEFT SIDE OF HOUSING		
3. Run Capacitor		<ul style="list-style-type: none"> a. Test run capacitor with a suitable capacitor tester for continuity, leakage short, and capacitance. b. The run capacitor is rated at 7.5 microfarads, 370 volts. c. Replace run capacitor if testing indicates that it is defective.
INSTALLATION		
4. Run Capacitor		<ul style="list-style-type: none"> a. Install run capacitor in capacitor bracket. b. Tighten capacitor bracket screw. c. Connect electrical leads to run capacitor and remove tags. d. Cover electrical leads with cap.
5. Left Side Panel		<ul style="list-style-type: none"> a. Align holes in left side panel with holes in housing. b. Secure left side panel with seventeen (17) screws.

4-28. START RELAY

This task covers:

- a. Removal
- b. Test

- c. Installation

INITIAL SETUP

Material/Parts

- Top Center Panel Screws (10)
- Top Rear Panel Screws (10)
- Start Relay Screw (1)
- Start Relay Nut (1)

References
None

Troubleshooting Reference

COMPRESSOR, Malfunction 1, Step 1

Approximate Time Required (in minutes)

Removal	15
Testing	10
Installation	15
TOTAL TIME	40

LOCATION/ITEM	REMARKS	ACTION
---------------	---------	--------

REMOVAL

TOP OF HOUSING

- | | |
|---|---|
| <p>1. Top Center Panel</p> <p>2. Top Rear Panel</p> | <p>a. Remove ten (10) screws securing top center panel to housing.</p> <p>b. Remove top center panel.</p> <p>a. Remove nine (9) screws securing top rear panel to housing.</p> <p>b. Remove top rear panel.</p> |
|---|---|

NOTE

The start relay may be tested while installed in the air conditioner. To gain access to the relay, remove and top rear panels.

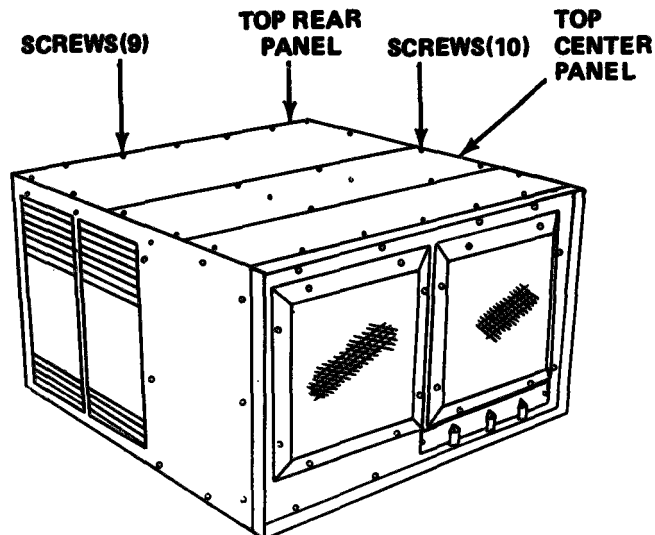

LOCATION/ITEM	REMARKS	ACTION
---------------	---------	--------

REMOVAL

TOP OF HOUSING

3. Start Relay

- a. Slip two (2) tywraps from around start relay.
- b. Remove protective cover.
- c. Tag and disconnect electrical leads from start relay.
- d. Remove one (1) screw and self-locking nut securing start relay to condenser shroud.
- e. Remove electrical lead and start relay.

TESTING

4. Start Relay

- a. Tag and disconnect electrical leads from start relay.
- b. Using an ohmmeter, measure continuity across start relay terminals.
- c. Replace start relay if there is NO continuity.

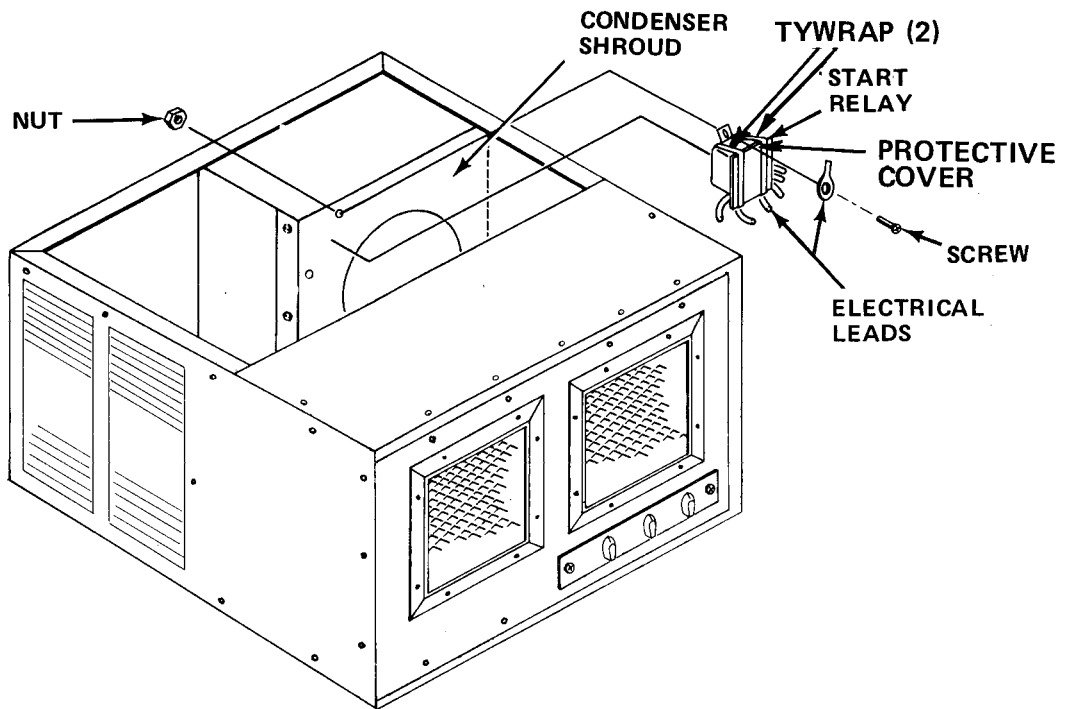

LOCATION/ITEM	REMARKS	ACTION
INSTALLATION		
TOP OF HOUSING		
5. Start Relay	<ul style="list-style-type: none"> a. Connect electrical leads to start relay and remove tags. b. Align hole in start relay with hole in condenser shroud. c. Secure electrical lead and start relay with one (1) screw and self-locking nut. d. Replace protective cover and secure with two (2) tywraps. 	
6. Top Rear Panel	<ul style="list-style-type: none"> a. Align holes in top rear panel and housing. b. Secure top rear panel with nine (9) screws. 	
7. Top Center Panel	<ul style="list-style-type: none"> a. Align holes in to center panel with holes in top rear and top front panels. b. Secure top center panel with ten (10) screws. 	

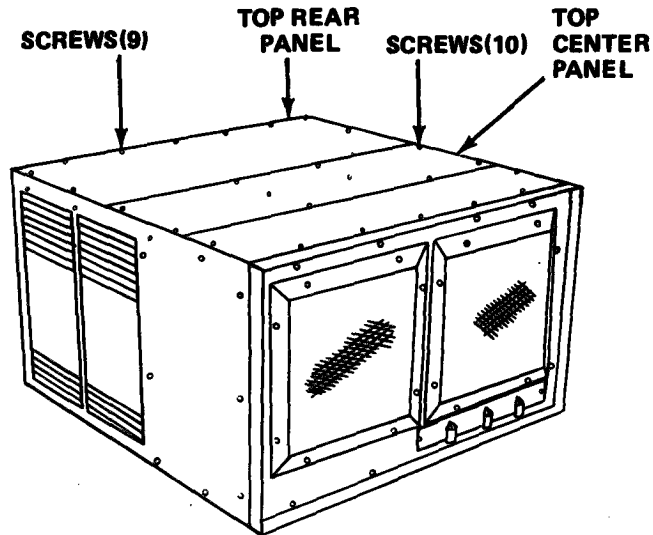

4-29. WIRING

This task covers:

- a. Removal
- b. Inspection
- c. Test
- d. Repair
- e. Installation

INITIAL SETUP

Material/Parts

- Top Center Panel Screws (10)
- Top Front Panel Screws (7)
- Top Rear Panel Screws (9)
- Right Side Panel Screws (17)
- Left Side Panel Screws (17)

References

Appendix F, Wiring Diagram

Troubleshooting Reference

COMPRESSOR, Malfunction 1, Step 2

Approximate Time Required (in minutes)

Removal	30
Inspection and Testing	30
Repair	30
Installation	30
TOTAL TIME	120

LOCATION/ITEM	REMARKS	ACTION
---------------	---------	--------

REMOVAL

TOP AND RIGHT SIDE OF HOUSING

- | | |
|--|--|
| <p>1. Top Center Panel</p> <p>2. Top Front Panel</p> <p>3. Top Rear Panel</p> <p>4. Right Side Panel</p> | <p>a. Remove ten (10) screws securing top center panel.</p> <p>b. Remove top center panel.</p> <p>a. Remove seven (7) screws securing top front panel.</p> <p>b. Remove top front panel.</p> <p>a. Remove nine (9) screws securing top rear panel.</p> <p>b. Remove top rear panel.</p> <p>a. Remove seventeen (17) screws securing right side panel.</p> <p>b. Remove right side panel.</p> |
|--|--|

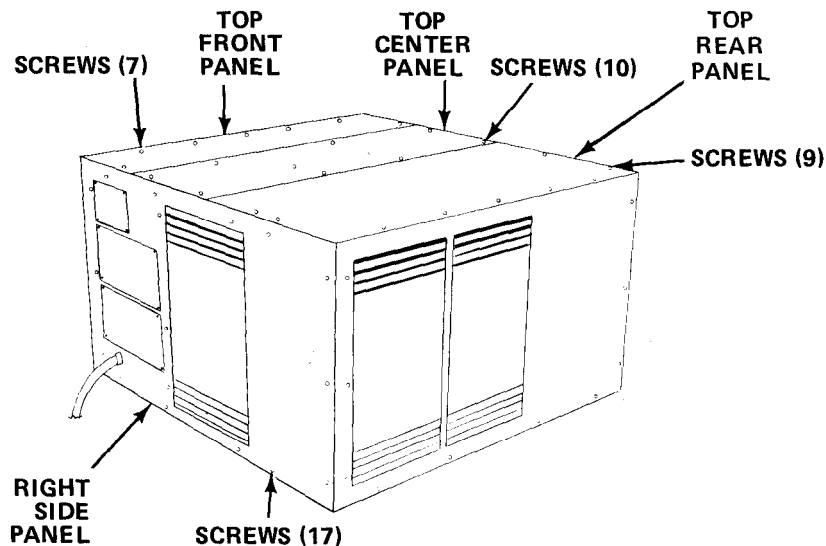

LOCATION/ITEM	REMARKS	ACTION
REMOVAL		
LEFT SIDE OF HOUSING		
5. Left Side Panel	<ul style="list-style-type: none"> a. Remove seventeen (17) screws securing left side panel to housing. b. Remove left side panel. 	
6. Wiring		Remove only those electrical leads or wires that show signs of damage.
INSPECTION AND TESTING		
HOUSING INTERIOR		
7. Electrical Leads	<ul style="list-style-type: none"> a. Inspect all electrical leads for cracked or frayed insulation material. b. Inspect all terminals for damaged condition. c. Disconnect each end of the following electrical leads and using a multimeter, set on low ohms scale, touch probes to ends of each electrical lead and verify that there is continuity (see Wiring Diagram, Appendix F): <ul style="list-style-type: none"> (1) K1-2 B1-START (2) K1-5 B1-COMMON (3) K1-1 C1 (4) K1-4 C1 (5) K1-4 S1-L1 (6) S1-2 S2-1 (7) S2-2 B1-RUN (8) K1-2 C2 (9) C2 S2-2 d. Repair or replace any electrical lead if there is NO continuity. 	
8. Power Cable	<ul style="list-style-type: none"> a. Inspect power cable for cracked or frayed insulation material. b. Inspect all terminals for damaged condition. c. Disconnect each of the power cable terminations and using a multimeter, set on low ohms scale, touch probes to each termination and their corresponding connector pin and verify that there is continuity (see Wiring Diagram, Appendix F): <ul style="list-style-type: none"> (1) K1-4 (2) K1-5 (3) GROUND d. Repair or replace power cable if there is NO continuity. 	
REPAIR		
9. Wiring	<ul style="list-style-type: none"> a. Remove insulation to expose 1/2 inch of bare wire on each side of break. b. Twist the wire ends together and solder the splice. c. Cover the splice with PVC electrical tape, making certain to cover all repaired areas. d. Replace broken terminal lugs with exact duplicates. 	

LOCATION/ITEM	REMARKS	ACTION
INSTALLATION		
TOP AND RIGHT SIDE OF HOUSING		
10. Right Side Panel		<ul style="list-style-type: none"> a. Align holes in right side panel with holes in housing. b. Secure right side panel with seventeen (17) screws.
11. Top Rear Panel		<ul style="list-style-type: none"> a. Align holes in top rear panel with holes in housing. b. Secure top rear panel with nine (9) screws.
12. Top Front Panel		<ul style="list-style-type: none"> a. Align holes in top front panel with holes in housing. b. Secure top front panel with seven (7) screws,
13. Top Center Panel		<ul style="list-style-type: none"> a. Align holes in top center panel with holes in top front and top rear panels. b. Secure top center panel with ten (10) screws,

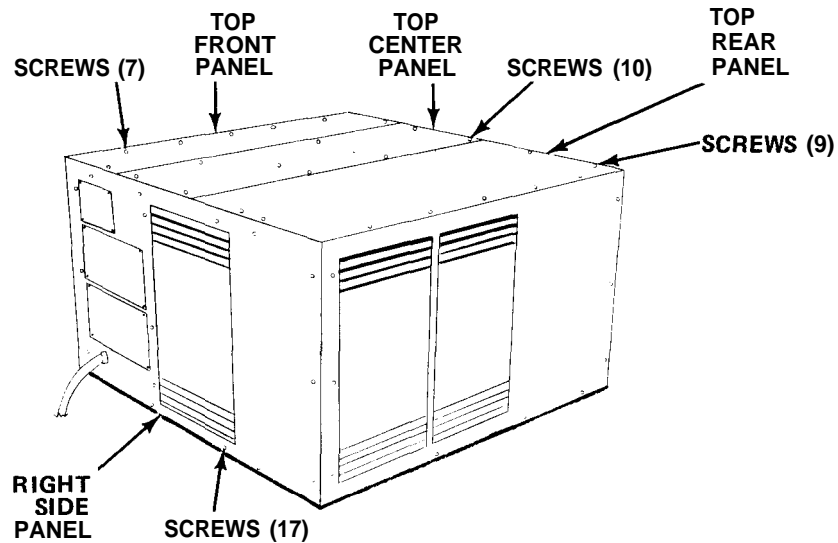

4-30. COMPRESSOR

This task covers:

- a. Removal
- b. Inspection

- c. Installation

INITIAL SETUP

Material/Parts
Left Side Panel Screws (17)

Troubleshooting Reference

AIR CONDITIONER, Malfunction 2, Step 4

Approximate Time Required (in minutes)

Removal	10
Inspection	5
Installation	10
TOTAL TIME	25

References
None

LOCATION/ITEM	REMARKS	ACTION
REMOVAL		
LEFT SIDE OF HOUSING		
1. Left Side Panel		<ul style="list-style-type: none"> a. Remove seventeen (17) screws securing left side panel to housing. b. Remove left side panel.
INSPECTION		
2. Compressor		<ul style="list-style-type: none"> a. Visually inspect compressor for damage. b. Inspect compressor tubing and fittings for leaks. c. Tighten fittings and report damaged condition to direct support maintenance personnel.
INSTALLATION		
3. Left Side Panel		<ul style="list-style-type: none"> a. Align holes in left side panel with holes in housing. b. Secure left side panel with seventeen (17) screws.

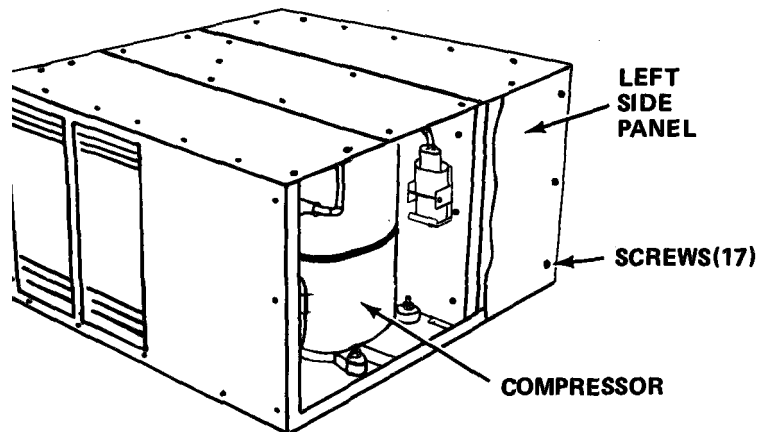

4-31. REFRIGERANT PIPING

This task covers:

- a. Removal
- b. Inspection
- c. Installation

INITIAL SETUP

Material/Parts

- Air Diffuser Grill Screws (8)
- Control Panel Plate Screws (2)
- Front Panel Screws (14)
- Top Center Panel Screws (10)
- Top Front Panel Screws (7)
- Top Rear Panel Screws (9)
- Right Side Panel Screws (17)
- Rear Panel Screws (14)
- Return Air Grill Screws (8)

References

None

Troubleshooting Reference

None

Approximate Time Required (in minutes)

Removal	30
Inspection	15
Installation	30
TOTAL TIME	75

LOCATION/ITEM	REMARKS	ACTION
---------------	---------	--------

REMOVAL

TOP AND LEFT SIDE OF HOUSING

- | | |
|---|--|
| <p>1. Top Center Panel</p> <p>2. Top Front Panel</p> <p>3. Top Rear Panel</p> <p>4. Left Side Panel</p> | <ul style="list-style-type: none"> a. Remove ten (10) screws securing top center panel. b. Remove top center panel.
 a. Remove seven (7) screws securing top front panel. b. Remove top front panel.
 a. Remove nine (9) screws securing top rear b. Remove top rear panel.
 a. Remove seventeen (17) screws securing left side panel. b. Remove left side panel. |
|---|--|

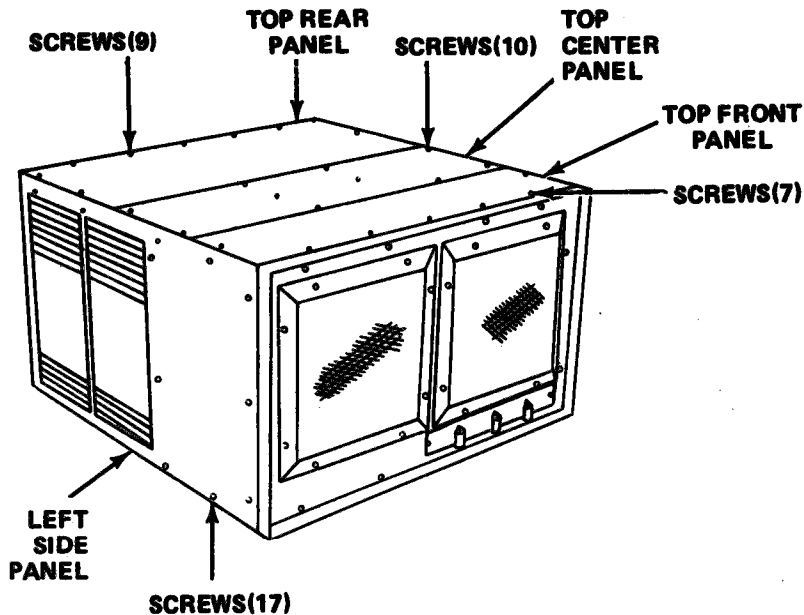

LOCATION/ITEM	REMARKS	ACTION
---------------	---------	--------

REMOVAL

RIGHT SIDE AND REAR OF HOUSING

5. Right Side Panel

- a. Remove seventeen (17) screws securing right side panel.
- b. Remove right side panel.

6. Rear Panel

- a. Remove fourteen (14) screws securing rear panel.
- b. Remove rear panel.

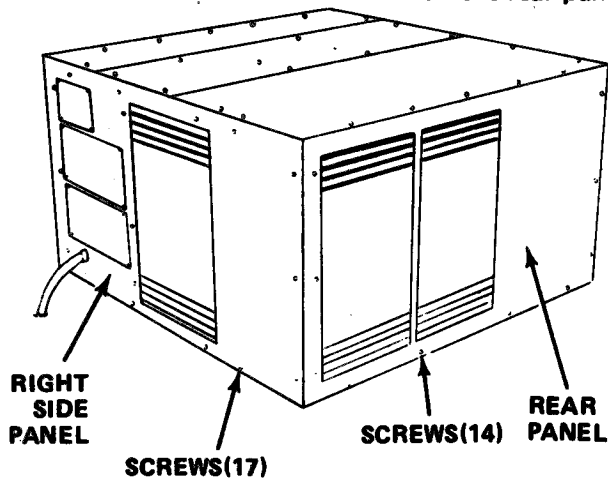

LOCATION/ITEM	REMARKS	ACTION
REMOVAL		
FRONT OF HOUSING		
7. Return Air Grill	<ul style="list-style-type: none"> a. Loosen mechanical screw post at rear of return air grill and remove wire. b. Remove eight (8) screws securing return air grill. c. Remove return air grill. 	
8. Air Diffuser Grill	<ul style="list-style-type: none"> a. Remove eight (8) screws securing air diffuser grill. b. Remove air diffuser grill. 	
9. Control Panel Plate	<ul style="list-style-type: none"> a. Loosen setscrews and remove knobs from fresh air control, selector switch and thermostat switch. b. Remove two (2) screws securing control panel plate. c. Remove control panel plate. 	
10. Front Panel	<ul style="list-style-type: none"> a. Remove two (2) screws securing thermostat switch to front panel. b. Remove fourteen (14) screws securing front panel. c. Remove front panel. 	

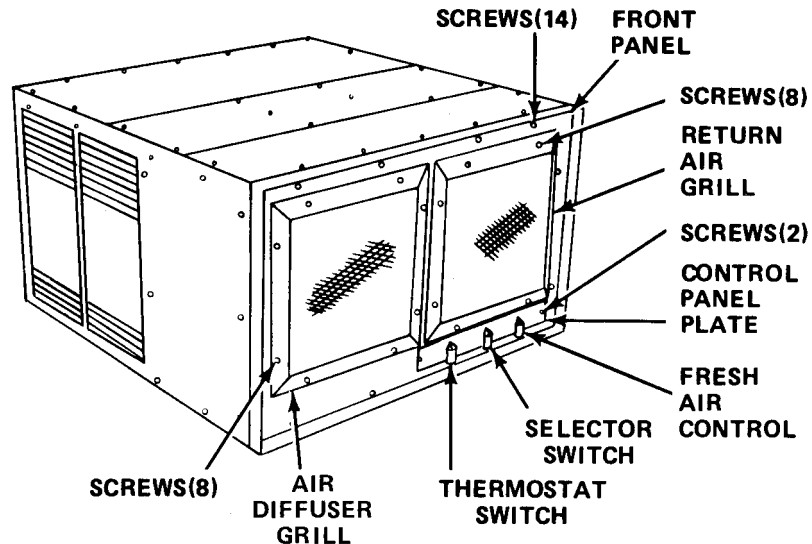

LOCATION/ITEM	REMARKS	ACTION
INSPECTION		
HOUSING INTERIOR		
11. Refrigerant Piping		<ul style="list-style-type: none"> a. Visually inspect all piping for damaged condition. b. Inspect all fittings for leaks. c. Tighten fittings and report damaged condition to direct support maintenance personnel.
INSTALLATION		
FRONT OF HOUSING		
12. Front Panel		<ul style="list-style-type: none"> a. Align holes in thermostat switch with holes in front panel. b. Secure thermostat switch to front panel with two (2) screws. c. Align holes in front panel with holes in housing. d. Secure front panel with fourteen (14) screws.
13. Control Panel Plate		<ul style="list-style-type: none"> a. Align holes in control panel plate with holes in front panel. b. Secure control panel plate with two (2) screws. c. Install three (3) knobs.
14. Air Diffuser Grill		<ul style="list-style-type: none"> a. Align holes in air diffuser grill with holes in front panel. b. Secure air diffuser grill with eight (8) screws.

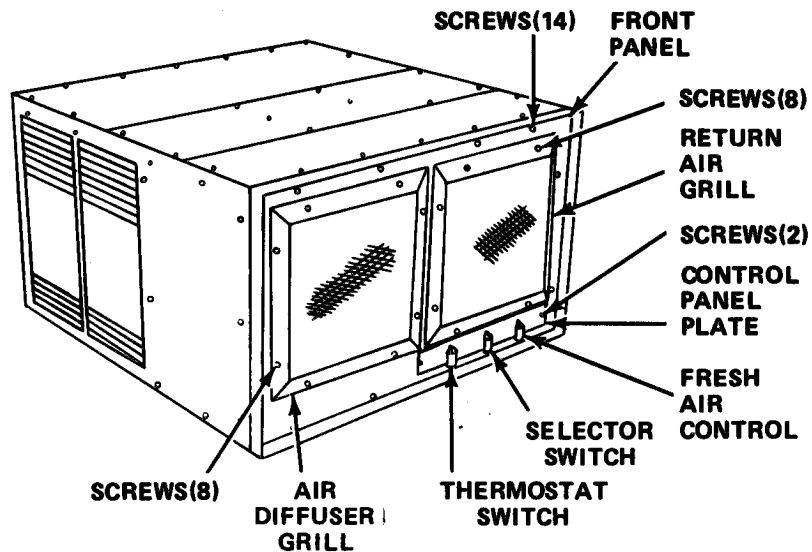

LOCATION/ITEM	REMARKS	ACTION
---------------	---------	--------

INSTALLATION

FRONT OF HOUSING

- | | |
|----------------------|---|
| 15. Return Air Grill | <ul style="list-style-type: none"> a. Align holes in return air grill with holes in front panel. b. Secure return air grill with eight (8) screws. c. Install wire in mechanical screw post and tighten mechanical screw post. |
|----------------------|---|

RIGHT SIDE AND REAR OF HOUSING

- | | |
|----------------------|---|
| 16. Rear Panel | <ul style="list-style-type: none"> a. Align holes in rear panel with holes in housing. b. Secure rear panel with fourteen (14) screws. |
| 17. Right Side Panel | <ul style="list-style-type: none"> a. Align holes in right side panel with holes in housing. b. Secure right side panel with seventeen (17) screws. |

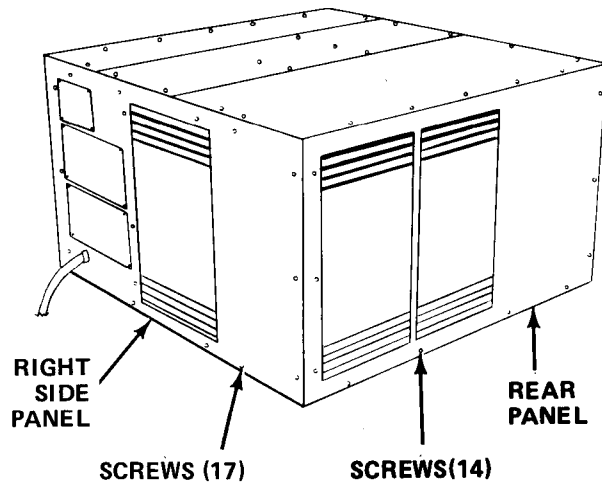

LOCATION/ITEM	REMARKS	ACTION
INSTALLATION		
TOP AND LEFT SIDE OF HOUSING		
18. Left Side Panel	<ul style="list-style-type: none"> a. Align holes in left side panel with holes in housing. b. Secure left side panel with seventeen (17) screws. 	
19. Top Rear Panel	<ul style="list-style-type: none"> a. Align holes in top rear panel with holes in housing. b. Secure top rear panel with nine (9) screws. 	
20. Top Front Panel	<ul style="list-style-type: none"> a. Align holes in top front panel with holes in housing. b. Secure top front panel with seven (7) screws. 	
21. Top Center Panel	<ul style="list-style-type: none"> a. Align holes in top center panel with holes in top front and top rear panels. b. Secure top center panel with ten (10) screws. 	

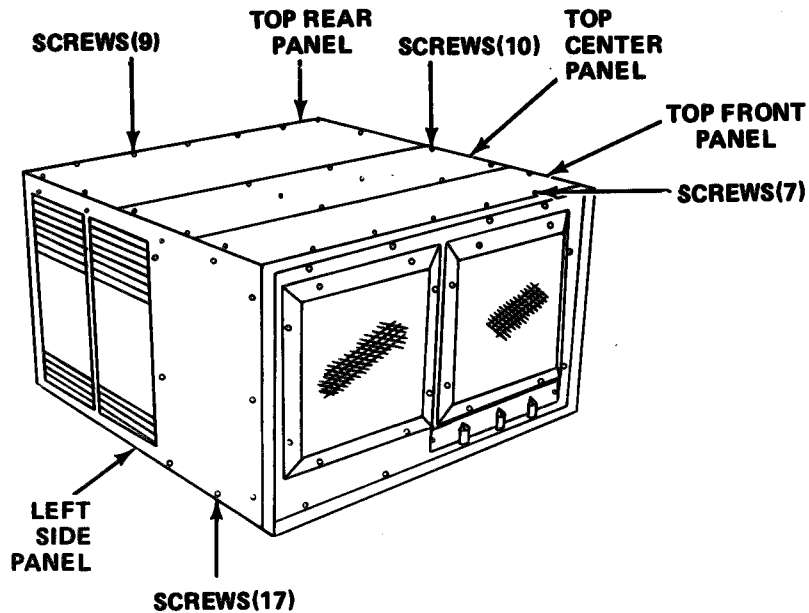

4-32. EVAPORATOR COIL

This task covers:

- a. Removal
- b. Inspection
- c. Service
- d. Installation

INITIAL SETUP

Material/Parts

- Air Diffuser Grill Screws (8)
- Left Side Panel Screws (17)
- Dry Cleaning Solvent

References

None

Troubleshooting Reference

AIR OUTPUT, Malfunction 1, Step 2

Approximate Time Required (in minutes)

Removal	10
Inspection and Service	10
Installation	10
TOTAL TIME	30

LOCATION/ITEM	REMARKS	ACTION
---------------	---------	--------

REMOVAL

FRONT AND LEFT SIDE OF HOUSING

- | | |
|--|--|
| <p>1. Air Diffuser Grill</p> <p>2. Left Side Panel</p> | <p>a. Remove eight (8) screws securing air diffuser grill to front panel.</p> <p>b. Remove air diffuser grill.</p> <p>a. Remove seventeen (17) screws securing left side panel to housing.</p> <p>b. Remove left side panel.</p> |
|--|--|

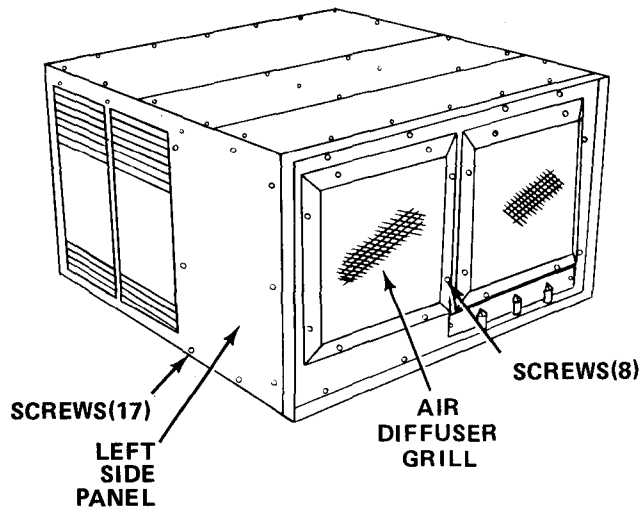

LOCATION/ITEM	REMARKS	ACTION
---------------	---------	--------

INSPECTION AND SERVICE

HOUSING INTERIOR

WARNING

Dry cleaning solvent, P-D-680 or P-S-661, used to clean parts is potentially dangerous to personnel and property. Avoid repeated and prolonged skin contact. Do not use near open flame or excessive heat. Flash point of solvent is 100° F (38° C).

WARNING

Do not use compressed air for cleaning purposes except where reduced to less than 30 psi and than only with effective chip guarding and personal protective equipment.

3. Evaporator Coil

- a. Inspect evaporator coil for cleanliness.
- b. Scrub the external portion of evaporator coil with a stiff bristle brush to remove scale and corrosion.
- c. Use low pressure compressed air to blow out loose material.
- d. Wipe evaporator coil with a cloth moistened with dry cleaning solvent, specification P-D-680 or P-S-661.
- e. Inspect evaporator coil for leaks.
- f. Straighten bent fins.
- g. Report damaged condition to direct support maintenance personnel.

LOCATION/ITEM	REMARKS	ACTION
---------------	---------	--------

INSTALLATION

FRONT AND LEFT SIDES OF HOUSING

- | | |
|-----------------------|--|
| 4. Air Diffuser Grill | <ul style="list-style-type: none"> a. Align holes in air diffuser grill with holes in front panel. b. Secure air diffuser grill with eight (8) screws. |
| 5. Left Side Panel | <ul style="list-style-type: none"> a. Align holes in left side panel with holes in housing. b. Secure left side panel with seventeen (17) screws. |

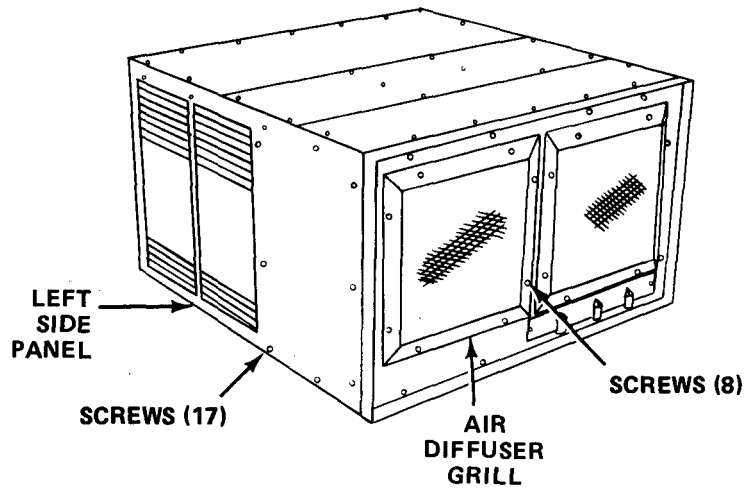

4-33. CONDENSER COIL

This task covers:

- a. Removal
- b. Inspection

- c. Service
- d. Installation

INITIAL SETUP

- Material/Parts**
- Rear Panel Screws (14)
 - Dry Cleaning Solvent

Troubleshooting Reference

- AIR CONDITIONER, Malfunction 2, Step 3
- AIR OUTPUT, Malfunction 2, Step 1

Approximate Time Required (in minutes)

Removal	10
Inspection and Service	10
Installation	10
TOTAL TIME	30

References
None

LOCATION/ITEM	REMARKS	ACTION
---------------	---------	--------

REMOVAL

REAR OF HOUSING

- 1. Rear Panel

- a. Remove fourteen (14) screws securing panel to housing.
- b. Remove rear panel.

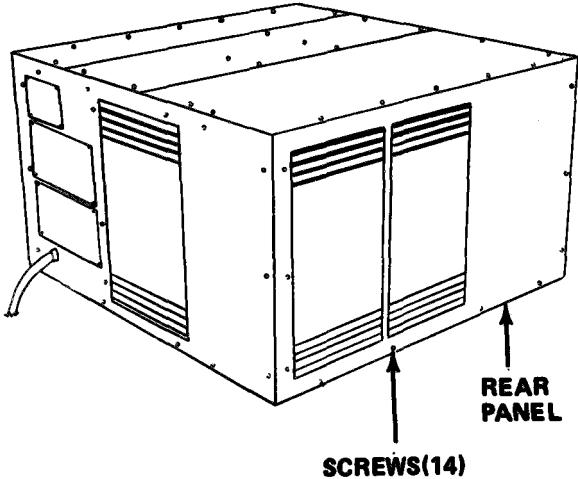

LOCATION/ITEM	REMARKS	ACTION
---------------	---------	--------

INSPECTION AND SERVICE

HOUSING INTERIOR

Dry cleaning solvent, P-D-680 or P-S-661, used to clean parts is potentially dangerous to personnel and property. Avoid repeated and prolonged skin contact Do not use near open flame or excessive heat Flash point o solvent is 100° F (38° C).

WARNING

Do not use compressed air for cleaning purposes except where reduced to less than 30 psi and then only with effective chip guarding and personal protective equipment

2. Condenser Coil

- a. Inspect condenser coil for cleanliness.
- b. Scrub the external portion of condenser coil with a stiff bristle brush to remove scale and corrosion.
- c. Use low pressure compressed air to blow out loose material.
- d. Wipe condenser coil with a cloth moistened with dry cleaning solvent, specification P-D-680 or P-S-661.
- e. Inspect condenser coil for leaks.
- f. Straighten bent fins.
- g. Report damaged condition to direct support maintenance personnel.

INSTALLATION

REAR OF HOUSING

3. Rear Panel

- a. Align holes in rear panel with holes in housing.
- b. Secure rear panel with fourteen (14) screws

4-34. SIGHT GLASS

This task covers:

- a. Removal
- b. Inspection
- c. Installation

INITIAL SETUP

Material/Parts
Rear Panel Screws (14)

Troubleshooting Reference

Approximate Time Required (in minutes)

Removal	10
Inspection	5
Installation	10
TOTAL TIME	25

References
None

LOCATION/ITEM	REMARKS	ACTION
---------------	---------	--------

NOTE

The sight glass may be inspected by looking through the louvers in the left side panel. If you cannot see the sight glass through the left side panel, then remove the rear panel.

REMOVAL

REAR OF HOUSING

- 1. Rear Panel
 - a. Remove fourteen (14) screws securing rear panel to housing.
 - b. Remove rear panel.

INSPECTION

- 2. Sight Glass
 - a. With air conditioner operating and providing cooling air, inspect sight glass.
 - b. Yellow appearance of humidity indicator indicates moisture in system. Bubbles or milky flow in refrigerant indicate low refrigerant charge.
 - c. Report presence of these conditions to direct support maintenance personnel.

LOCATION/ITEM	REMARKS	ACTION
INSTALLATION		
3. Rear Panel		a. Align holes in rear panel with holes in housing. b. Secure rear panel with fourteen (14) screws.

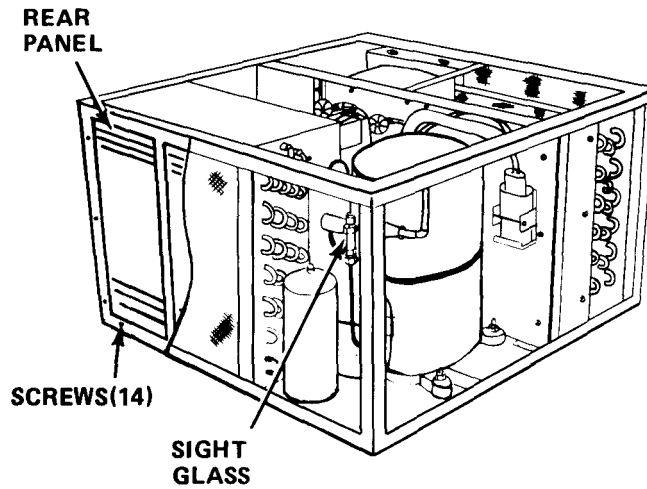

4-35. EXPANSION VALVE

This task covers:

- a. Removal
- b. Inspection

- c. Installation

INITIAL SETUP

Material/Parts

- Top Center Panel Screws (10)
- Top Front Panel Screws (7)
- Right Side Panel Screws (17)

Troubleshooting Reference

None

Approximate Time Required (in minutes)

Removal	10
Inspection	10
Installation	10
TOTAL TIME	30

References
None

LOCATION/ITEM	REMARKS	ACTION
---------------	---------	--------

REMOVAL

TOP AND RIGHT SIDE OF HOUSING

- | | |
|--|---|
| <ul style="list-style-type: none"> 1. Top Center Panel 2. Top Front Panel 3. Right Side Panel | <ul style="list-style-type: none"> a. Remove ten (10) screws securing top center panel. b. Remove top center panel. a. Remove seven (7) screws securing top front panel. b. Remove top front panel. a. Remove seventeen (17) screws securing right side panel. b. Remove right side panel. |
|--|---|

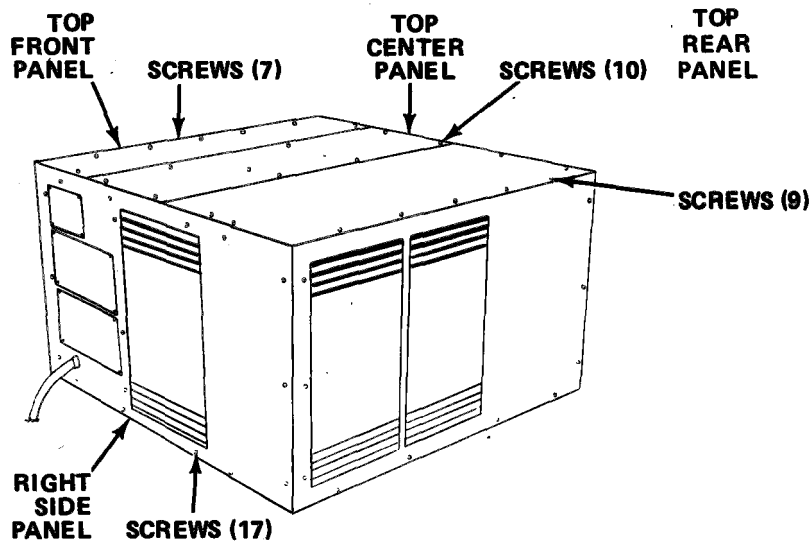

LOCATION/ITEM	REMARKS	ACTION
---------------	---------	--------

INSPECTION

HOUSING INTERIOR

- | | |
|--------------------|---|
| 4. Expansion Valve | <ul style="list-style-type: none"> a. Inspect expansion valve for cracked or damaged condition. b. Inspect capillary tube for kinks or breaks. c. Inspect sensing bulb for security of attachment and be sure it is completely covered with insulation tape. d. Report damaged condition to direct support maintenance personnel. |
|--------------------|---|

INSTALLATION

TOP AND RIGHT SIDE OF HOUSING

- | | |
|---------------------|---|
| 5. Right Side Panel | <ul style="list-style-type: none"> a. Align holes in right side panel with holes in housing. b. Secure right side panel with seventeen (17) screws. |
| 6. Top Front Panel | <ul style="list-style-type: none"> a. Align holes in top front panel with holes in housing. b. Secure top front panel with seven (7) screws. |
| 7. Top Center Panel | <ul style="list-style-type: none"> a. Align holes in top center panel with holes in top front and top rear panels. b. Secure top center panel with ten (10) screws. |

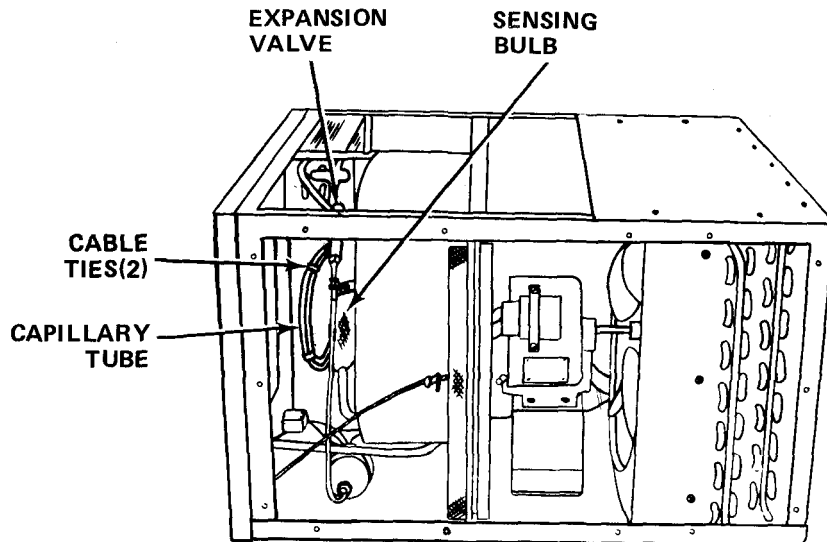

4-36. PREPARATION FOR STORAGE OF SHIPMENT

Disconnect the power cable. Unbolt the air conditioner from mounting brackets. It will be desirable to cover the air conditioner during transit. Crate the air conditioner for long-distance movement.

- a. No special preservation, packaging, packing, marking, or shipping requirements are associated with the storage or shipment of the unit.
- b. The use of corrosion-preventive compounds, moisture barriers, and dessicant materials is not required.
- c. Before placing the unit in storage, the next scheduled preventive maintenance checks and services should be performed, and all known deficiencies corrected.

CHAPTER 5

DIRECT SUPPORT MAINTENANCE INSTRUCTIONS

CHAPTER OVERVIEW

This chapter contains all the necessary maintenance instructions for direct support maintenance personnel to keep your air conditioner in good repair.

INDEX

	Para	Page
Common Tools and Equipment	5-2	5-1
Consumable Materials	5-4	5-1
Direct Support Maintenance Procedures	5-7	5-4
Direct Support Troubleshooting	5-5	5-2
Direct Support Troubleshooting Table	5-6	5-2
Maintenance Repair Parts	5-1	5-1
Special Tools and Test Equipment	5-3	5-1

Section I. REPAIR PARTS, SPECIAL TOOLS, TMDE, AND SUPPORT EQUIPMENT

5-1. MAINTENANCE REPAIR PARTS

Repair parts for the air conditioner are listed and illustrated in TM 5-4120-341-23P.

5-2. COMMON TOOLS AND EQUIPMENT

For common tools and equipment, refer to the Table of Organization and Equipment (TOE).

5-3. SPECIAL TOOLS AND TEST EQUIPMENT

No special tool or test equipment are required.

5-4. CONSUMABLE MATERIALS

Item No.	Name	Specification
5	Refrigerant	R-12

Section II. DIRECT SUPPORT TROUBLESHOOTING

5-5. GENERAL

a. This section provides information useful in diagnosing and correcting unsatisfactory operation or failure of the air conditioner. Each malfunction is followed by a list of probable causes and actions to take to remedy the malfunction. You should perform the tests/inspections and corrective actions in the order listed.

b. This manual cannot list all malfunctions that may occur; nor all tests or inspections and corrective actions. If a malfunction is not listed or is not corrected by listed corrective actions, notify your supervisor.

5-6. DIRECT SUPPORT TROUBLESHOOTING TABLE

Malfunction	Test or Inspection	Corrective Action
-------------	--------------------	-------------------

COMPRESSOR

1. COMPRESSOR WILL NOT START

- Step 1.* Check compressor for proper operation and damage.
Replace defective compressor (para. 5-9).

2. COMPRESSOR CYCLES INTERMITTENTLY

- Step 1.* Inspect sight glass for proper amount of refrigerant.
Add refrigerant as required (para. 5-8).
- Step 2.* Check for high discharge pressure.
Discharge refrigerant from system (para. 5-8).
- Step 3.* Check for air in refrigerant system.
Purge refrigerant system (para. 5-8).

AIR CONDITIONER

1. HIGH DISCHARGE PRESSURE

- Step 1.* Check for excessive refrigerant in system.
Discharge refrigerant from system (para. 5-8).
- Step 2.* Check for air in refrigerant system.
Purge refrigerant system (para. 5-8).

2. LOW DISCHARGE PRESSURE

- Step 1.* Check to see if compressor is pumping.
Replace defective compressor (para. 5-9).
- Step 2.* Inspect sight glass for proper amount of refrigerant.
Add refrigerant as required (para. 5-8).

3. INSUFFICIENT COOLING

- step 1.* Inspect sight glass for proper amount of refrigerant.
Add refrigerant as required (para. 5-8).
- Step 2.* Check to see if dehydrator is clogged or defective.
Remove restriction or replace dehydrator (para. 5-13).
- step 3.* Check for air in refrigerant system.
Purge refrigerant system (para. 5-8).
- Step 4.* Inspect expansion valve for proper operation and damage.
Replace defective expansion valve (para. 515).

4. LOW SUCTION PRESSURE

- step 1.* Inspect expansion valve for proper operation.
Replace defective expansion valve (para. 5-15).
- step 2.* Check to see if dehydrator is clogged or defective.
Remove restriction or replaced dehydrator (para. 5-13).

5. LOW SUCTION AND DISCHARGE PRESSURE

- step 1.* Inspect sight glass for proper amount of refrigerant.
Add refrigerant as required (para. 5-8).
 - Step 2.* Inspect refrigerant piping for leaks.
Repair leaks or replace piping (para. 5-10).
 - step 3.* Inspect expansion valve for proper operation and damage.
Replace defective expansion valve (para 5-15).
-

Section III. DIRECT SUPPORT OPERATOR'S MAINTENANCE PROCEDURES

INDEX

	Page	Page
Compressor	5-9	5-11
Condenser Coil	5-12	5-38
Dehydrator	5-13	5-43
Evaporator Coil	5-11	5-28
Expansion Valve	5-15	5-47
General	5-7	5-4
Refrigerant Piping	5-10	5-18
Refrigerant Servicing	5-8	5-5
Sight Glass	5-14	5-45

5-7. GENERAL

The following information pertains to all procedures for the direct support maintenance personnel.

INITIAL SETUP

Applicable Configurations

All

Test Equipment

None

Special Tools

Recovery & Recycling Unit, Refrigerant

Personnel Required

Direct Support Maintenance

Special Environmental Conditions

In accordance with Environmental Protection Agency regulations refrigerants cannot be discharged into the atmosphere. A refrigerant recovery & recycling unit must be used whenever discharging the refrigerant system.

General Safety Instructions

Disconnect the power source before performing any maintenance function. Do not use compressed air for cleaning purposes except where reduced to less than 30 psi and then only with effective chip guarding and personal protective equipment.

5-8. REFRIGERANT SERVICING

This task covers:

- a. Removal
- b. Test
- c. Service
- d. Installation

INITIAL SETUP

Material/Parts

- Top Center Panel Screws (10)
- Dry Nitrogen
- Refrigerant R-12
- Rear Panel Screws (14)

Troubleshooting Reference

- COMPRESSOR, Malfunction 2, Step 1
- COMPRESSOR, Malfunction 2, Step 2
- COMPRESSOR, Malfunction 2, Step 3
- AIR CONDITIONER, Malfunction 1, Step 1
- AIR CONDITIONER, Malfunction 1, Step 2
- AIR CONDITIONER, Malfunction 3, Step 1
- AIR CONDITIONER, Malfunction 3, Step 3
- AIR CONDITIONER, Malfunction 5, Step 1

Approximate Time Required (in minutes)

	10
Test	30
Service	720
Installation	10
TOTAL TIME	770

References

Paragraph 5-13

LOCATION/ITEM

REMARKS

ACTION

REMOVAL

TOP AND REAR OF HOUSING

- | | |
|---------------------|---|
| 1. Top Center Panel | <ul style="list-style-type: none"> a. Remove ten (10) screws securing top center panel. b. Remove top center panel. |
| 2. Rear Panel | <ul style="list-style-type: none"> a. Remove fourteen (14) screws securing rear panel. b. Remove rear panel. |

LOCATION/ITEM	REMARKS	ACTION
---------------	---------	--------

TESTING

TOP OF HOUSING

3. Refrigerant System

- a. Remove caps from discharge and suction service valves.
- b. Pressure check the refrigerant system as follows:
 - (1) Connect suction pressure gauge to suction service valve.
 - (2) Start air conditioner.
 - (3) Connect discharge pressure gauge to discharge service valve.
 - (4) Open discharge and suction service valves,
 - (5) Compare gauge readings with the normal range of system pressure as shown in the following table.
 - (6) Close discharge and discharge service valves,
 - (7) Remove gauges and install valve caps.

Normal Operating Pressures

	Outdoor Ambient Temperature	
	<i>120° F/125° F (48.9° C/57.7° C)</i>	<i>95° F (35° C)</i>
	AT 90° F/75° F (32.2° C/23.9° C) DB return air to unit	
Suction Pressure	54-64 psi (374-443 kPa)	
Discharge Pressure	230-260 psi (1592-1799 kPa)	
	AT 80° F/67° F (26.7° C/19.4° C) DB return air to unit	
Suction Pressure	38-49 psi (263-339 kPa)	
Discharge Pressure	160-185 psi (1107-1280 kPa)	

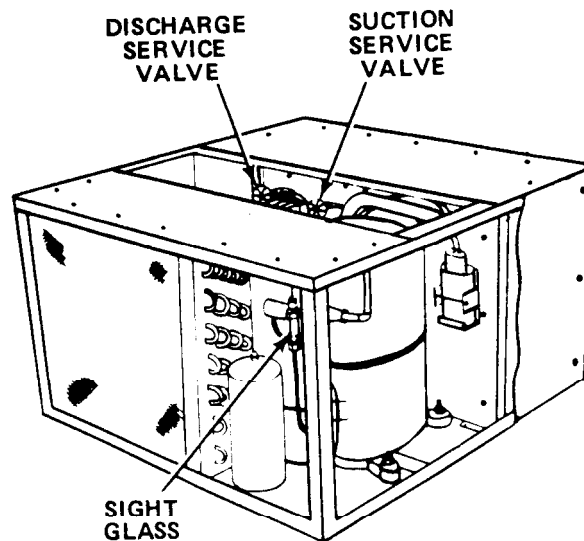

LOCATION/ITEM	REMARKS	ACTION
---------------	---------	--------

SERVICE

TOP OF HOUSING

WARNING

Avoid bodily contact with liquid refrigerant and avoid inhaling refrigerant gas. Be especially careful that Refrigerant 12 does not come in contact with eyes. In case of refrigerant leaks, ventilate area immediately.

4. Discharge Refrigerant System

NOTE

- In accordance with Environmental Protection Agency regulations, refrigerants cannot be discharged into the atmosphere. A refrigerant recovery&recycling unit must be used whenever discharging the refrigerant system.
- Operation of the recovery/recycling unit must be by AUTHORIZED PERSONNEL ONLY.

Connect and operate a recovery/recycling unit in accordance with the manufacturer's instructions.

5. Dehydrator

Refer to paragraph 5-13 and replace dehydrator.

6. Purge Refrigerant System

- a. Remove valve cap from discharge and suction service valves.
- b. Using proper nitrogen regulator connect a cylinder of dry nitrogen to suction service valve.
- c. Attach suitable hose to discharge service valve.
- d. Open both suction and discharge service valves.
- e. Open valve on nitrogen cylinder and allow nitrogen to flow through refrigerant system until all moisture is forced out. Do not exceed 5 psig.
- f. Close nitrogen cylinder valve.
- g. Close suction and discharge service valves.
- h. Remove nitrogen cylinder and discharge hose.
- i. Using bar manifold, connect vacuum pump to center hose. Using proper hoses, connect suction service valve to suction pressure gage.
- j. Turn on vacuum pump, open service valves and hold a 29.0 inch Hg vacuum for eight (8) hours.
- k. Close suction and discharge service valves.
- l. Turn off vacuum pump.
- m. Remove hoses from suction and discharge valves.
- n. Remove vacuum pump and install valve caps.

7. Soldering Procedure

- a. Solder all copper-to-copper joints with silver solder type 3, 4 or 6A per specification QQ-S-561.
- b. Solder all copper-to-brass or copper-to-steel with type 4 or 6A per specification QQ-S-561.
- c. Solder melting point is 1160°F (625°C).
- d. Make all solder joints with an atmosphere of inert gas to prevent internal oxidation.

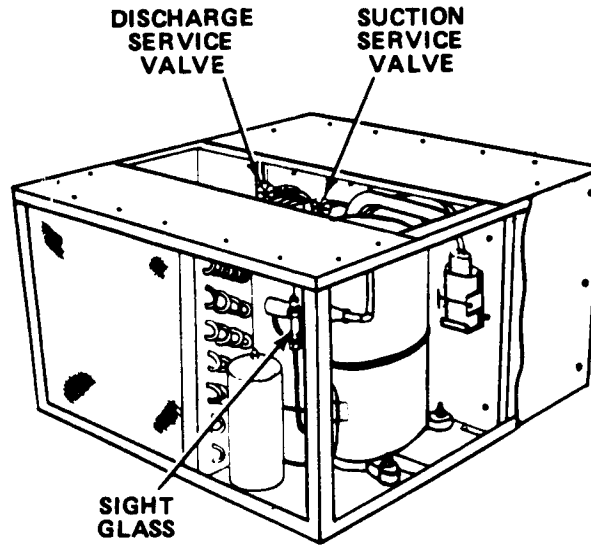

LOCATION/ITEM	REMARKS	ACTION
---------------	---------	--------

SERVICE

TOP OF HOUSING

WARNING

Avoid bodily contact with liquid refrigerant and avoid inhaling refrigerant gas. Be especially careful that Refrigerant 12 does not come in contact with eyes. In case of refrigerant leaks, ventilate area immediately.

NOTE

- Whenever available, use recycled refrigerant for charging the refrigeration system.
- The following steps *a.* through *L.* apply only to a completely evacuated system. To add additional refrigerant to a charged system, refer to steps *f.* through *j.*

8. Charging Refrigerant System

- a.* Remove valve cap from suction discharge valve.
- b.* Place inverted refrigerant drum on scale and note weight of drum.
- c.* Loosely connect the charging line of refrigerant drum to suction discharge valve.
- d.* Partially open refrigerant drum valve and purge air from charging line.
- e.* Close refrigerant drum valve and tighten connection at suction discharge valve.

CAUTION

DO NOT operate air conditioner while charging the refrigerant system.

- f.* Open suction discharge valve.
- g.* Open refrigerant drum valve and charge refrigerant system until system and drum pressures are equal or until 3.5 pounds of refrigerant have entered the system.

LOCATION/ITEM	REMARKS	ACTION
SERVICE		
TOP OF HOUSING		
8. Charging Refrigerant System (continued)		<ul style="list-style-type: none"> <i>h.</i> Close refrigerant drum valve and suction discharge valves. <i>i.</i> Carefully loosen connection at suction discharge valve to release trapped pressure. <i>i.</i> Disconnect charging line and install valve cap on suction discharge valve. <i>k.</i> Operate air conditioner in cooling mode for 15 minutes. <i>l.</i> Check sight glass for gas bubbles. If gas bubbles are present, add additional refrigerant (steps m. through v.) <i>m.</i> Place the same refrigerant drum on a scale in an upright position on a scale. <i>n.</i> Remove valve cap from suction service valve. <i>o.</i> Loosely connect charging line to suction service valve. <i>p.</i> Partially open refrigerant drum valve and purge air from charging line. <i>q.</i> Close refrigerant drum valve and tighten connection at suction service valve.

CAUTION

Add refrigerant slowly to avoid slugging at the compressor.

- r.* With air conditioner operating in the cooling mode, open discharge valve and refrigerant drum valve and add approximately one (1) ounce per minute of refrigerant. Constantly observe sight glass and when bubbles disappear close suction service valve.
- s.* Close refrigerant drum valve.
- t.* Carefully loosen charging line to release trapped pressure.

- u.* Disconnect charging line and install valve cap on suction service valve.

LOCATION/ITEM	REMARKS	ACTION
---------------	---------	--------

INSTALLATION

TOP AND REAR OF HOUSING

9. Rear Panel

- a. Align holes in rear panel with holes in housing.
- b. Secure rear panel with fourteen (14) screws.

10. Top Center Panel

- a. Align holes in top center panel with holes in top front panel and top rear panel.
- b. Secure top center panel with ten (10) screws.

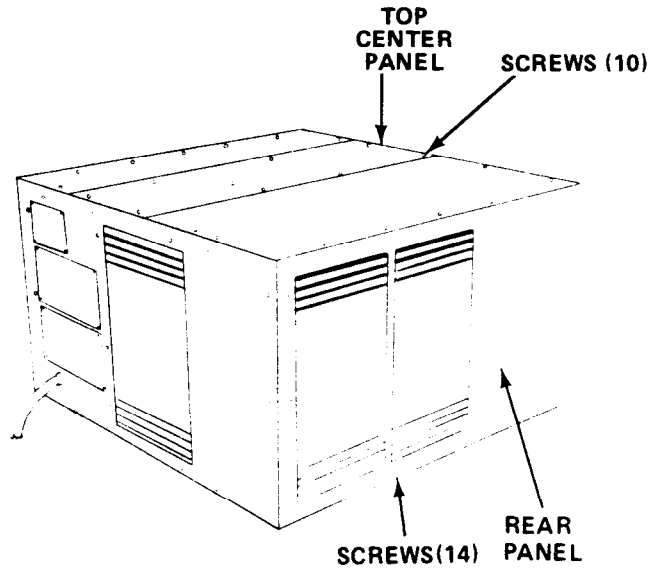

5-9. COMPRESSOR

This task covers:

- a. Removal
- b. Test
- c. Service
- d. Repair
- e. Installation

INITIAL SETUP

Material/Parts

- Top Center Panel Screws (10)
- Top Rear Panel Screws (9)
- Rear Panel Screws (14)
- Nuts (4)
- Capscrews (4)
- Flat Washers (8)

References

- Paragraph 2-12
- Paragraph 2-14
- Paragraph 5-8
- Paragraph 5-13

Troubleshooting Reference

- COMPRESSOR, Malfunction 1, Step 1
- AIR CONDITIONER, Malfunction 1, Step 1

Approximate Time Required (in minutes)

Removal	30
Test	30
Service	720
Repair	60
Installation	30
TOTAL TIME	870

LOCATION/ITEM

REMARKS

ACTION

REMOVAL

1. Top Center Panel

- a. Remove ten (10) screws securing top center panel to top front and top rear panels.
- b. Remove top center panel.

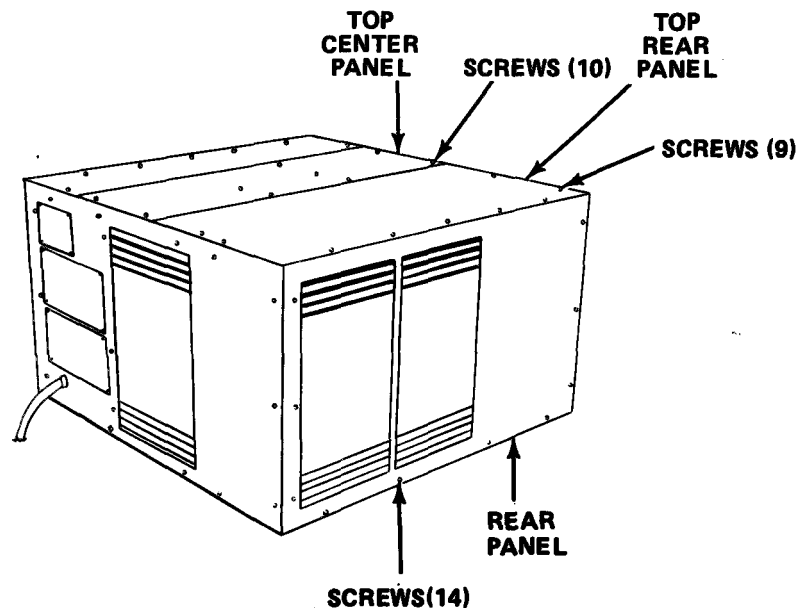

LOCATION/ITEM	REMARKS	ACTION
REMOVAL		
2. Top Rear Panel		a. Remove nine (9) screws securing top rear panel to housing. b. Remove top rear panel.
3. Rear Panel		a. Remove fourteen (14) screws securing rear panel to housing. b. Remove rear panel.
LEFT SIDE OF HOUSING		
4. Left Side Panel		a. Remove seventeen (17) screws securing left side panel to housing. b. Remove left side panel.
NOTE		
Testing of the compressor is to be done while the air conditioner is operating and supplying cooling air.		
5. Refrigerant Servicing		Refer to paragraph 5-8 and discharge refrigerant system.

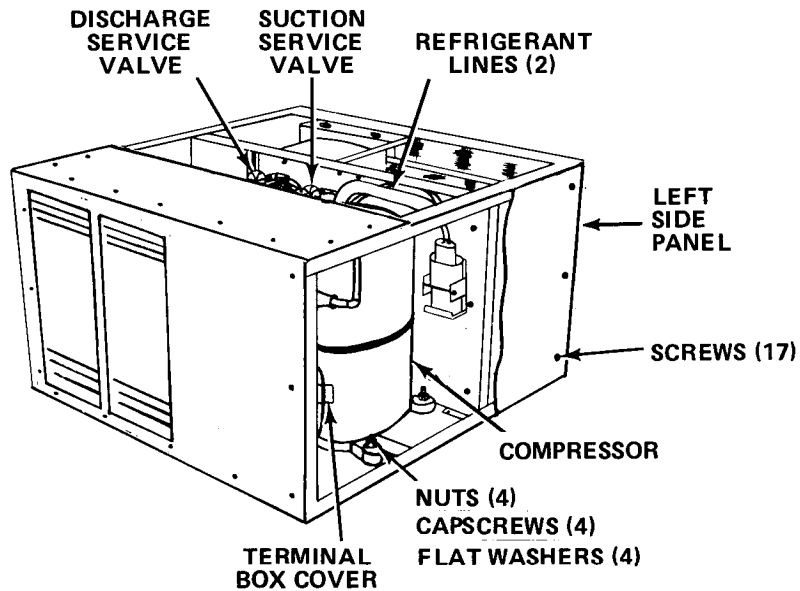

LOCATION/ITEM	REMARKS	ACTION
REMOVAL		
6. Compressor		<ul style="list-style-type: none">a. Unscrew and remove flare nut connecting suction refrigerant line to compressor.b. Remove suction refrigerant line from compressor.c. Unsolder and remove discharge line from compressor.d. Remove four (4) nuts, capscrews and eight (8) flatwashers securing compressor to housing.e. Tag and disconnect electrical leads from compressor.f. Remove compressor from housing through left side.

LOCATION/ITEM	REMARKS	ACTION
<p>SERVICE</p>	<p>8. Compressor Burnout Procedure</p>	<ul style="list-style-type: none"> a. If the compressor is mechanically frozen or has sustained a motor burnout, "replace the compressor. b. Flush out the entire refrigeration system as follows or repeated burnouts will occur. <ul style="list-style-type: none"> (1) Refer to paragraph 5-8 and discharge refrigerant system. (2) Purge refrigerant system with dry nitrogen (paragraph 5-8). (3) Remove defective compressor. (4) With compressor removed, purge refrigerant system with dry nitrogen (paragraph 5-8). (5) Install new compressor. (6) Install new dehydrator (paragraph 5-13). (7) Discharge refrigerant system three (3) times (paragraph 5-8). (8) Start and operate air conditioner for twenty-four (24) hours (paragraph 2-12). (9) Stop air conditioner (paragraph 2-14). (10) Discharge refrigerant system and purge with dry nitrogen (paragraph 5-8). (11) Remove dehydrator and install a new one (paragraph 5-13). (12) Discharge refrigerant system and recharge with refrigerant (paragraph 5-8). (13) Operate air conditioner.

LOCATION/ITEM	REMARKS	ACTION
---------------	---------	--------

REPAIR

9. Compressor

- a. Tighten loose connections.
- b. Repair damaged wiring by removing insulation to expose 1/2 inch of bare wire on each side of break.
- c. Twist the wire ends together and solder the splice.
- d. Cover the splice with PVC electrical tape, making certain to cover all repaired areas.

INSTALLATION

TOP AND LEFT SIDE OF HOUSING

10. Compressor

- a. Install compressor through left side of housing.
- b. Align holes in compressor mounting feet with holes in housing.
- c. Secure compressor with eight (8) flatwashers, four (4) capscrews and four (4) nuts.
- d. Install two (2) refrigerant lines on compressor and tighten flare nut on suction refrigerant line.
- e. Refer to paragraph 5-8 and solder discharge refrigerant line.

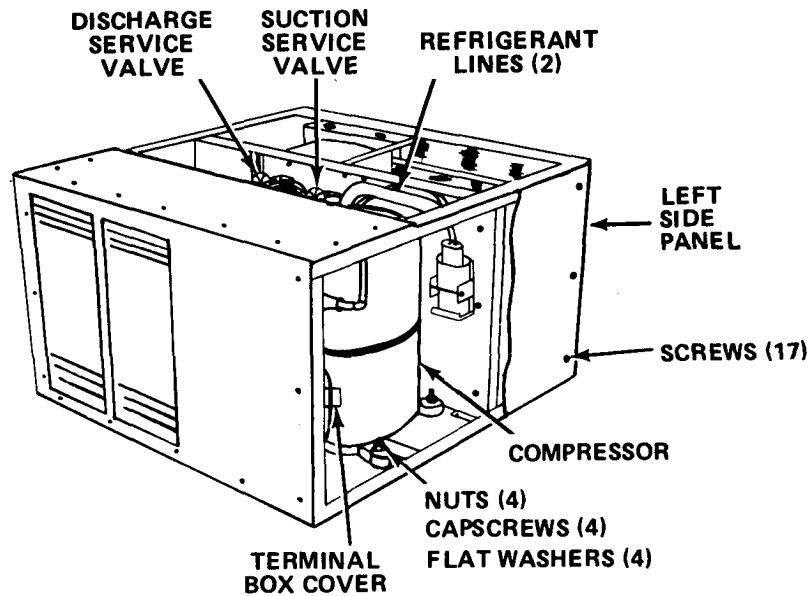

LOCATION/ITEM	REMARKS	ACTION
---------------	---------	--------

INSTALLATION

TOP AND REAR OF HOUSING

- | | |
|------------------------|--|
| 11. Rear Panel | <ul style="list-style-type: none"> a. Align holes in rear panel with holes in housing. b. Secure rear panel with fourteen (14) screws. |
| 12. Top Rear Panel | <ul style="list-style-type: none"> a. Align holes in top rear panel with holes in housing. b. Secure top rear panel with nine (9) screws. |
| 13. Refrigerant System | <p>Refer to paragraph 5-8 and charge refrigerant system. Refer to burnout procedure if a burnout has been detected.</p> |
| 14. Top Center Panel | <ul style="list-style-type: none"> a. Align holes in top center panel with holes in top rear panel and top front panel. b. Secure top center panel with ten (10) screws. |

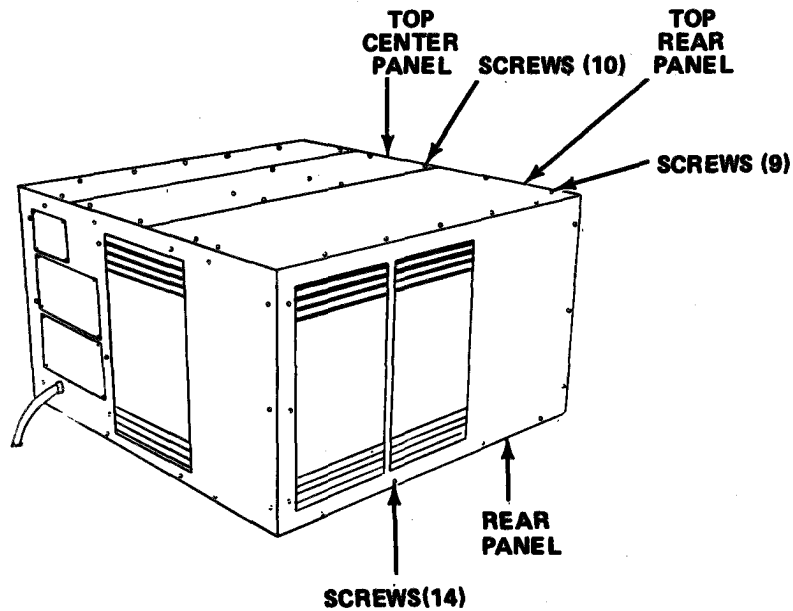

5-10. REFRIGERANT PIPING AND SERVICE VALVES

This task covers:

- a Removal
- b. Test

- c. Repair
- d Installation

INITIAL SETUP

Material/Parts

- Top Center Panel Screws (10)
- Top Front Panel Screws (7)
- Top Rear Panel Screws (9)
- Right Side Panel Screws (17)
- Rear Panel Screws (14)
- Left Side Panel Screws (17)
- Return Air Grill Screws (8)
- Air Diffuser Grill Screws (8)
- Control Panel Plate Screws (2)
- Front Panel Screws (14)

References

Paragraph 5-8

Troubleshooting Reference

AIR CONDITIONER, Malfunction 5, Step 2

Approximate Time Required (in minutes)

Removal	20
Testing and Repair	30
Installation	750
TOTAL TIME	800

LOCATION/ITEM

REMARKS

ACTION

REMOVAL

TOP AND LEFT SIDE OF HOUSING

- | | |
|---------------------|---|
| 1. Top Center Panel | <ul style="list-style-type: none"> a. Remove ten screws securing top center panel. b. Remove top center panel. |
| 2. Top Front Panel | <ul style="list-style-type: none"> a. Remove seven (7) screws securing top front panel. b. Remove top front panel. |
| 3. Top Rear Panel | <ul style="list-style-type: none"> a. Remove nine (9) screws securing top rear panel. b. Remove top rear panel. |
| 4. Left Side Panel | <ul style="list-style-type: none"> a. Remove seventeen (17) screws securing left side panel. b. Remove left side panel. |

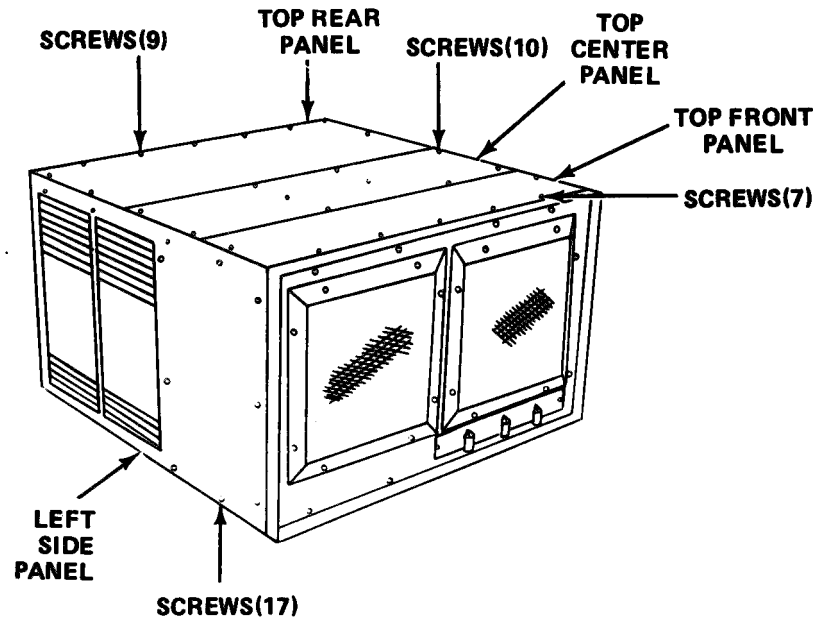

LOCATION/ITEM	REMARKS	ACTION
REMOVAL		
RIGHT SIDE AND REAR OF HOUSING		
5. Right Side Panel	<ul style="list-style-type: none"> a. Remove seventeen (17) screws securing right side panel. b. Remove right side panel. 	
6. Rear Panel	<ul style="list-style-type: none"> a. Remove fourteen (14) screws securing rear b. Remove rear panel. 	
FRONT OF HOUSING		
7. Control Panel Plate	<ul style="list-style-type: none"> a. Loosen setscrews and remove knobs from fresh air control, selector switch and thermostat switch. b. Remove two (2) screws securing control panel plate. c. Remove control panel plate. 	

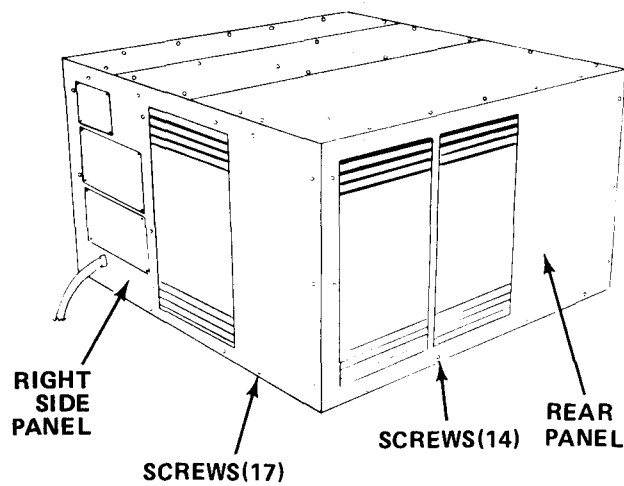

LOCATION/ITEM	REMARKS	ACTION
REMOVAL		
FRONT OF HOUSING		
8. Return Air Grill	<ul style="list-style-type: none"> a. Loosen mechanical screw post at door and remove wire. b. Loosen clamp on evaporator shroud and remove wire. c. Remove eight (8) screws securing return air grill. d. Remove return air grill. 	
9. Air Diffuser Grill	<ul style="list-style-type: none"> a. Remove eight (8) screws securing air diffuser grill. b. Remove air diffuser grill. 	
10. Front Panel	<ul style="list-style-type: none"> a. Remove two (2) screws securing thermostat switch to front panel. b. Remove fourteen (14) screws securing front panel. c. Remove front panel. 	
11. Refrigerant System	Refer to paragraph 5-8 and discharge refrigerant system.	

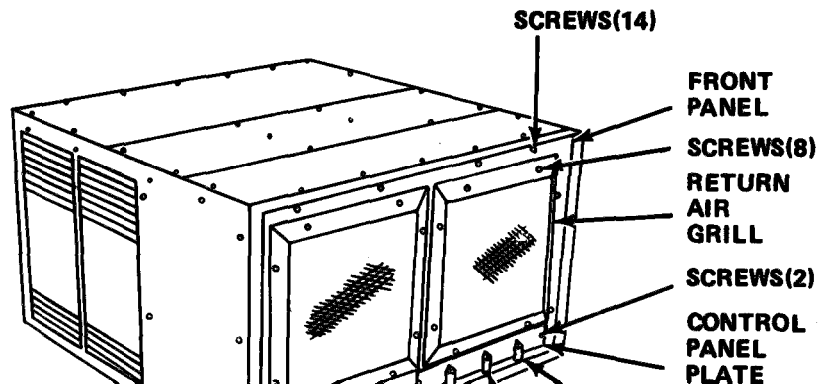

LOCATION/ITEM	REMARKS	ACTION
REMOVAL		
INTERIOR OF HOUSING		
12. Service Valves	<ul style="list-style-type: none"> a. Unscrew and remove flare nuts from suction and discharge service valves. b. Remove refrigerant lines from suction and discharge service valves. c. Remove two (2) screws from each service valve. d. Remove suction and discharge service valves. 	
13. Refrigerant Piping	<ul style="list-style-type: none"> a. Unsolder and remove tubing only when necessary to remove a defective part. b. When soldering, constantly purge the refrigerant system with dry nitrogen to prevent scale formation within the refrigerant system (paragraph 5-8). 	

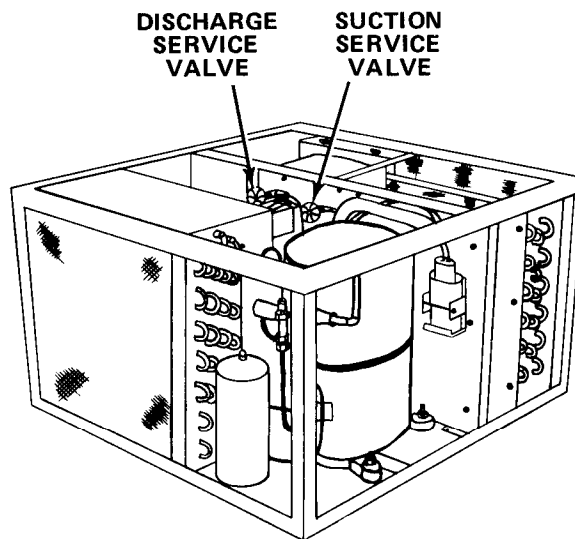

LOCATION/ITEM	REMARKS	ACTION
INSPECTION		
HOUSING INTERIOR		
14. Refrigerant Piping	a.	Visually inspect all piping for kinks, cracks or splits.
	b.	Inspect all fittings for leaks.
15. Valves	a.	Visually inspect all valves for signs of damage.
	b.	Inspect valve fittings for leaks.
TESTING AND REPAIR		
WARNING		
<p>Avoid bodily contact With liquid refrigerant and avoid inhaling refrigerant gas. Be especially careful that refrigerant does not come in contact with eyes. In case of refrigerant leaks, ventilate area immediately.</p>		
16. Refrigerant Piping	a.	Check all piping and connections with a General Electrical Type H-2 Halogen Test Detector (or approved equal).
	b.	Calibrate the detector with a General Electric LS-20 leak standard (or approved equal) for a pure refrigerant leak rate of 0.1 ounce per year.
	c.	Replace any piping or connection that is leaking.
INSTALLATION		
17. Refrigerant Piping	a.	Solder all copper-to-copper joints with silver solder type 3, 4 or 6A per specification QQ-S-561.
	b.	Solder all copper-to-brass or copper-to-steel with type 4 or 6A per specification QQ-S-561.
	c.	Solder melting point is 1160° F (625° C).
	d.	Make all solder joints with an atmosphere of inert gas to prevent internal oxidation.
18. Service Valves	a.	Connect suction and discharge service valves to refrigerant piping.
	b.	Tighten flare nuts at suction and discharge service valves.
	c.	Secure suction and discharge service valves to bulkhead with four (4) screws.
FRONT OF HOUSING		
19. Front Panel	a.	Align holes in thermostat switch with holes in front panel.
	b.	Secure thermostat to front panel with two (2) screws.
	c.	Align holes in front panel with holes in housing.
	d.	Secure front panel with fourteen (14) screws.

LOCATION/ITEM	REMARKS	ACTION
INSTALLATION		
FRONT OF HOUSING		
20. Air Diffuser Grill		<ul style="list-style-type: none"> a. Align holes in air diffuser grill with holes in front panel. b. Secure air diffuser grill with eight (8) screws.
21. Return Air Grill		<ul style="list-style-type: none"> a. Align holes in return air grill with holes in front panel. b. Secure return air grill with eight (8) screws. c. Install wire through clamp on evaporator shroud and tighten clamp. d. Install wire in mechanical screw post on door and tighten mechanical screw post.
22. Control Panel Plate		<ul style="list-style-type: none"> a. Align holes in control panel plate with holes in front panel. b. Secure control panel plate with two (2) screws. c. Install three (3) knobs.

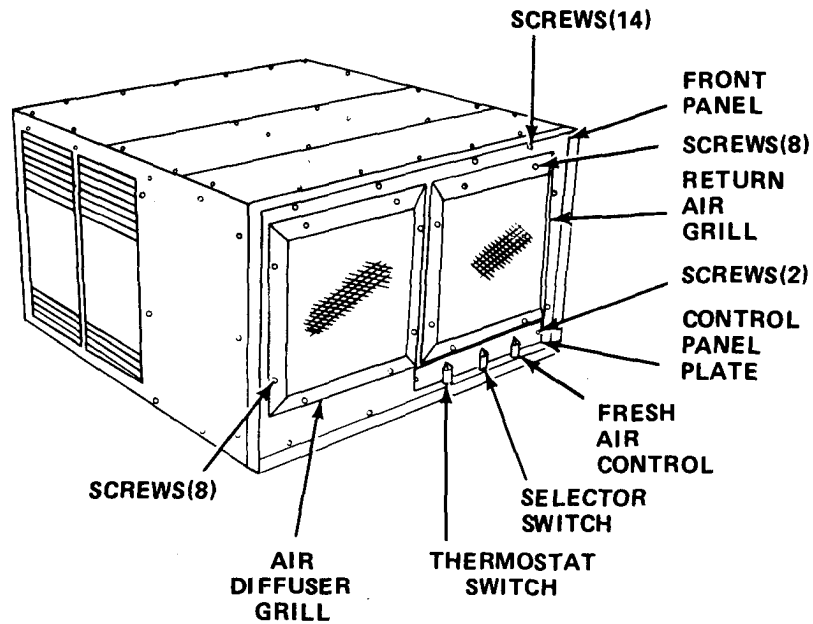

LOCATION/ITEM	REMARKS	ACTION
---------------	---------	--------

INSTALLATION

RIGHT SIDE AND REAR OF HOUSING

23. Rear Panel

- a. Align holes in rear panel with holes in housing.
- b. Secure rear panel with fourteen (14) screws.

24. Right Side Panel

- a. Align holes in right side panel with holes in housing.
- b. Secure right side panel with seventeen (17) screws.

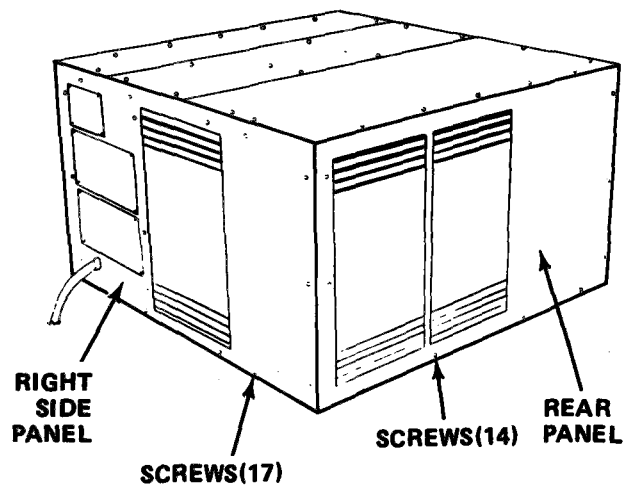

LOCATION/ITEM	REMARKS	ACTION
INSTALLATION		
TOP AND LEFT SIDE OF HOUSING		
25. Left Side Panel	<ul style="list-style-type: none"> a. Align holes in left side panel with holes in housing. b. Secure left side panel with seventeen (17) screws. 	
26. Top Rear Panel	<ul style="list-style-type: none"> a. Align holes in top rear panel with holes in housing. b. Secure top rear panel with nine (9) screws. 	
27. Top Front Panel	<ul style="list-style-type: none"> a. Align holes in top front panel with holes in housing. b. Secure top front panel with seven (7) screws. 	
28. Refrigerant Servicing	Refer to paragraph 5-8 and charge refrigerant system.	
29. Top Center Panel	<ul style="list-style-type: none"> a. Align holes in top center panel with holes in top front and top rear panels. b. Secure top center panel with ten (10) screws. 	

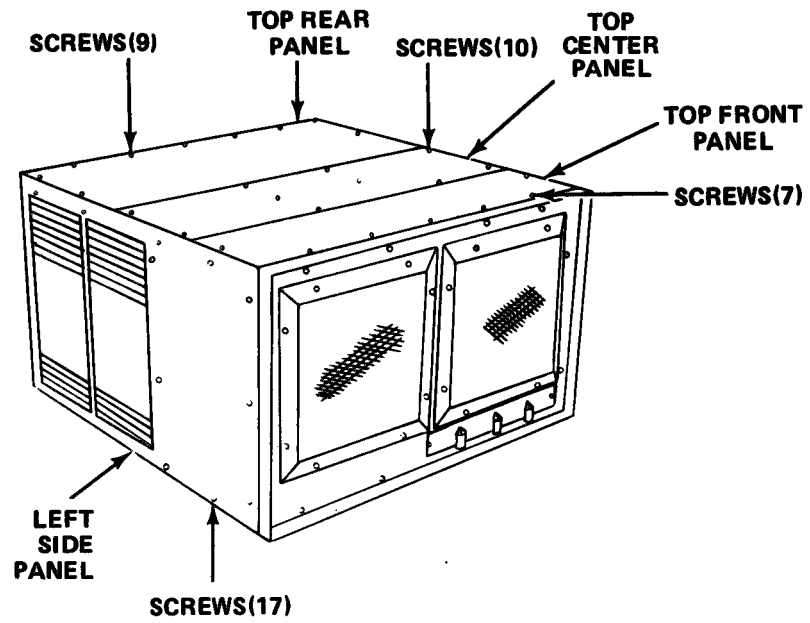

5-11. EVAPORATOR COIL

This task covers:

- a. Removal
- b. Test

- c. Repair
- d. Installation

INITIAL SETUP

Material/Parts

- Top Center Panel Screws (10)
- Top Front Panel Screws (7)
- Top Rear Panel Screws (9)
- Right Side Panel Screws (17)
- Rear Panel Screws (14)
- Left Side Panel Screws (17)
- Thermostat Switch Screws (2)
- Selector Switch Screws (2)
- Control Panel Plate Screws (2)
- Front Panel Screws (14)
- Condenser Shroud Screws (2)
- Frame Screws (8)
- Evaporator Coil Screws (6)
- Evaporator Coil Screws (4)

References

Paragraph 5-8

Troubleshooting Reference

None

Approximate Time Required (in minutes)

Removal	30
Test	20
Repair	20
Installation	720
TOTAL TIME	790

LOCATION/ITEM

REMARKS

ACTION

REMOVAL

TOP AND LEFT SIDE OF HOUSING

- | | |
|---------------------|---|
| 1. Top Center Panel | <ul style="list-style-type: none"> a. Remove ten (10) screws securing top center panel. b. Remove top center panel. |
| 2. Top Front Panel | <ul style="list-style-type: none"> a. Remove seven (7) screws securing top front panel. b. Remove top front panel. |
| 3. Top Rear Panel | <ul style="list-style-type: none"> a. Remove nine (9) screws securing top rear panel. b. Remove top rear panel. |
| 4. Left Side Panel | <ul style="list-style-type: none"> a. Remove seventeen (17) screws securing left side panel. b. Remove left side panel. |

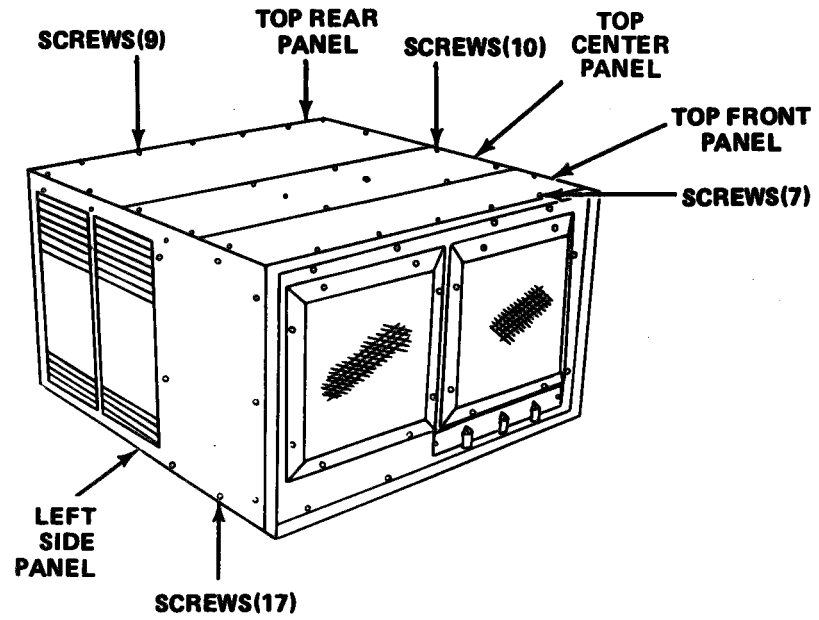

LOCATION/ITEM	REMARKS	ACTION
---------------	---------	--------

REMOVAL

RIGHT SIDE AND REAR OF HOUSING

- | | |
|---------------------|---|
| 5. Right Side Panel | a. Remove seventeen (17) screws securing right side panel.
b. Remove right side panel. |
| 6. Rear Panel | a. Remove fourteen (14) screws securing rear panel.
b. Remove rear panel. |

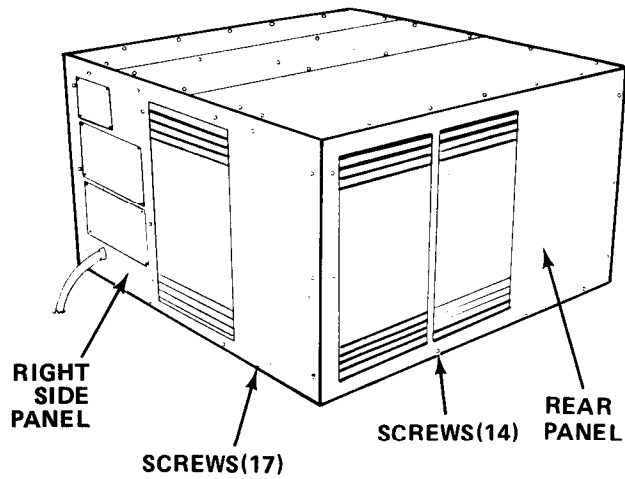

LOCATION/ITEM	REMARKS	ACTION
REMOVAL		
FRONT OF HOUSING		
7. Control Panel Plate	<ul style="list-style-type: none"> a. Loosen setscrews and remove knobs from fresh air control, selector switch and thermostat switch. b. Remove two (2) screws securing control panel plate. c. Remove control panel plate. 	
8. Front Panel	<ul style="list-style-type: none"> a. Loosen mechanical screw post at door and remove wire. b. Loosen clamp on evaporator shroud and remove wire. c. Remove two (2) screws securing thermostat switch to front panel. d. Remove two (2) screws securing selector switch to front panel. e. Remove fourteen (14) screws securing front panel. f. Remove front panel. 	

NOTE

Test evaporator coil for leaks prior to discharging refrigerant system and removing evaporator coil.

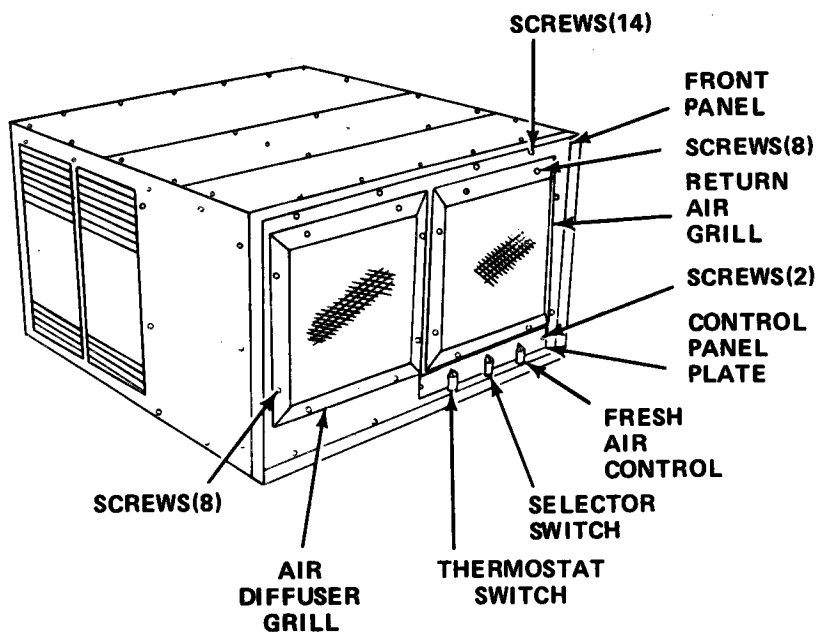

LOCATION/ITEM	REMARKS	ACTION
---------------	---------	--------

REMOVAL

HOUSING INTERIOR

9. Evaporator Coil

- a. Remove two (2) screws at top of frame securing condenser shroud to frame.
- b. Remove screw on top of frame securing suction line clamp.
- c. Remove eight (8) screws securing frame to base.
- d. Remove frame from base.
- e. Remove air filter.
- f. Unsolder suction line approximately two (2) inches below header and remove suction line from evaporator coil.
- g. Unscrew and remove flare nut between expansion valve and evaporator coil.
- h. Remove six (6) screws securing evaporator coil to bulkhead.
- i. Remove four (4) screws from underside of base that secure evaporator coil to base.
- j. Remove evaporator coil.

TESTING

10. Evaporator Coil

- a. Check all evaporator coil tubing and sweat fittings with a General Electric Type H-2 Halogen Test Detector (or approved equal).
- b. Calibrate the detector with a General Electric LS-20 leak standard (or approved equal) for a pure refrigerant leak rate of 0.1 ounce per year.
- c. Mark all spots where leaks are noticed.
- d. Repair leaks or replace evaporator coil.

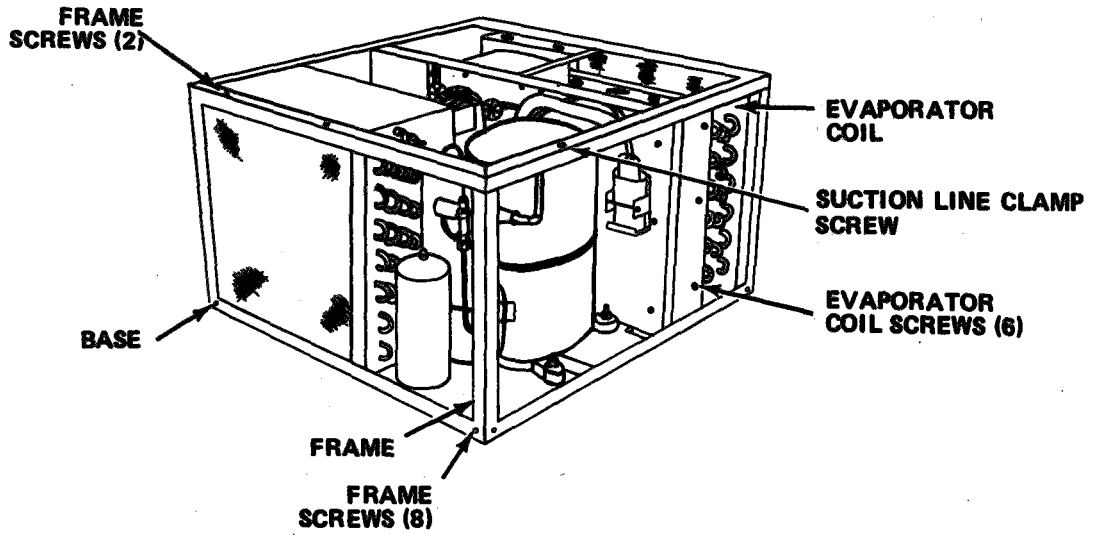

LOCATION/ITEM	REMARKS	ACTION
---------------	---------	--------

WARNING

Purge system with dry nitrogen prior to soldering. Refrigerant heated to 1200° F creates phosgene gas.

REPAIR

- | | |
|---------------------|--|
| 11. Evaporator Coil | <ul style="list-style-type: none"> a. Repair minor leaks or holes by soldering. b. Use a silver solder with a 50% silver capacity and a melting point of approximately 1160° F (634.8° C). c. Straighten bent fins prior to installation. |
|---------------------|--|

INSTALLATION

HOUSING INTERIOR

- | | |
|---------------------|---|
| 12. Evaporator Coil | <ul style="list-style-type: none"> a. Align holes in evaporator coil with holes in base. b. Secure evaporator coil to base from the underside using four (4) screws. c. Secure evaporator coil to bulkhead with six (6) screws. d. Connect and solder two (2) refrigerant lines to evaporator coil. e. Align holes in frame with holes in base. f. Secure frame to base with eight (8) screws. g. Secure frame to condenser coil with two (2) screws. h. Connect suction line to evaporator coil approximately two (2) inches below header. i. Refer to paragraph 5-8 and solder suction line. j. Connect refrigerant line between evaporator coil and expansion valve and tighten flare nut. |
|---------------------|---|

INSTALLATION

FRONT OF HOUSING

- | | |
|-----------------|---|
| 13. Front Panel | <ul style="list-style-type: none"> a. Align holes in thermostat switch with holes in front panel. b. Secure thermostat switch to front panel with two (2) screws. c. Align holes in selector switch with holes in front panel. d. Secure selector switch to front panel with two (2) screws. e. Align holes in front panel with holes in housing. f. Secure front panel with fourteen (14) screws. g. Install wire in mechanical screw post on door and tighten mechanical screw post. h. Install wire through clamp on evaporator shroud and tighten clamp. |
|-----------------|---|

LOCATION/ITEM	REMARKS	ACTION
---------------	---------	--------

INSTALLATION

FRONT OF HOUSING

14. Control Panel Plate

- a. Align holes in control panel plate withholds in front panel.
- b. Secure control panel plate with two (2) screws.
- c. Install three (3) knobs.

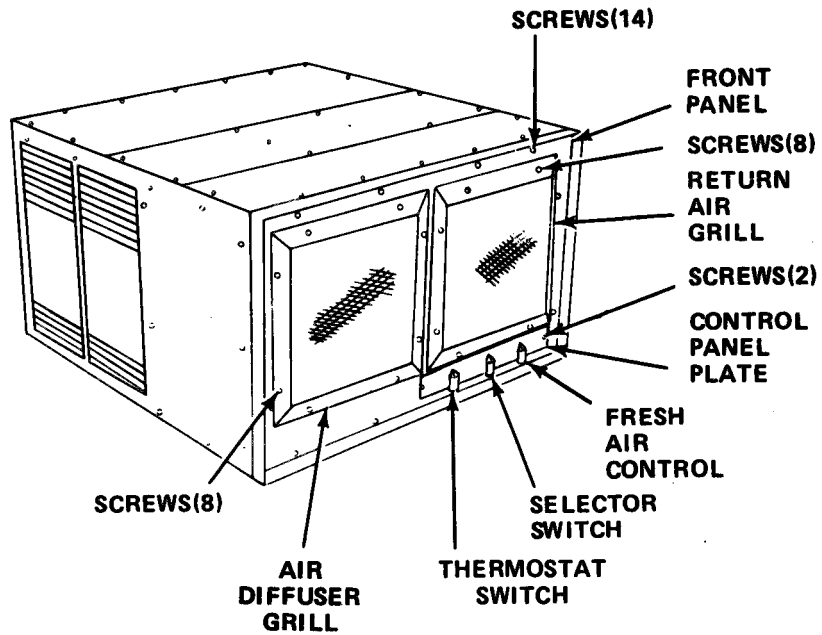

LOCATION/ITEM	REMARKS	ACTION
---------------	---------	--------

INSTALLATION

RIGHT SIDE AND REAR OF HOUSING

- | | |
|----------------------|---|
| 15. Rear Panel | <ul style="list-style-type: none"> a. Align holes in rear panel with holes in housing. b. Secure rear panel with fourteen (14) screws. |
| 16. Right Side Panel | <ul style="list-style-type: none"> a. Align holes in right side panel with holes in housing. b. Secure right side panel with seventeen (17) screws. |

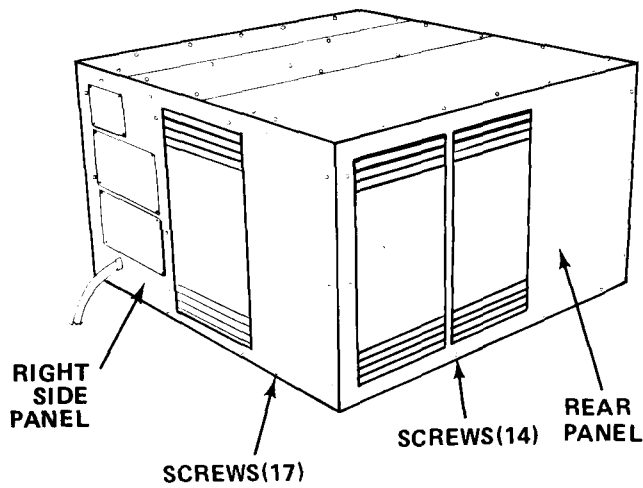

LOCATION/ITEM	REMARKS	ACTION
---------------	---------	--------

INSTALLATION

TOP AND LEFT SIDE OF HOUSING

- | | |
|---------------------------|---|
| 17. Left Side Panel | <ul style="list-style-type: none"> a. Align holes in left side panel with holes in housing. b. Secure left side panel with seventeen (17) screws. |
| 18. Top Rear Panel | <ul style="list-style-type: none"> a. Align holes in top rear panel with holes in housing. b. Secure top rear panel with nine (9) screws. |
| 19. Top Front Panel | <ul style="list-style-type: none"> a. Align holes in top front panel with holes in housing. b. Secure top front panel with seven (7) screws. |
| 20. Refrigerant Servicing | Refer to paragraph 5-8 and charge refrigerant system. |
| 21. Top Center Panel | <ul style="list-style-type: none"> a. Align holes in top center panel with holes in top front and top rear panels. b. Secure top center panel with ten (10) screws. |

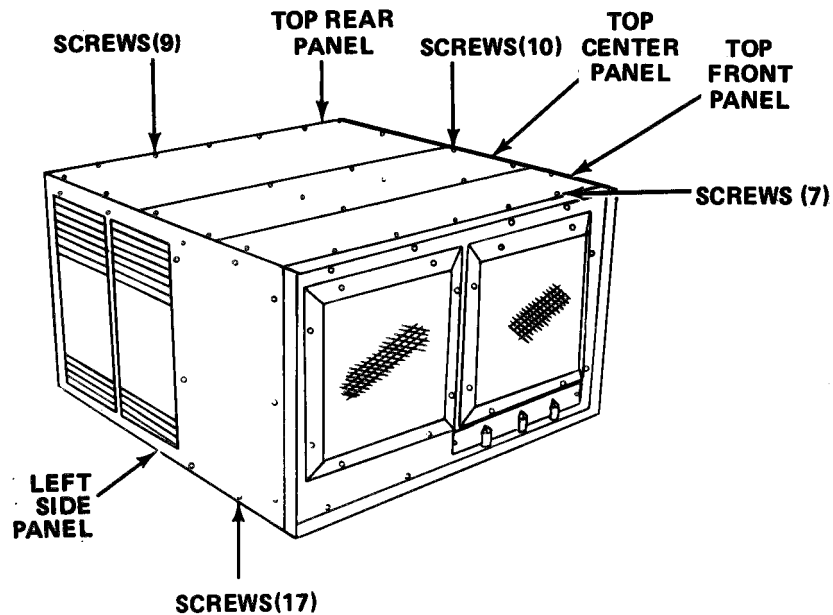

5-12. CONDENSER COIL

This task covers:

- a. Removal
- b. Test
- c. Repair
- d. Installation

INITIAL SETUP

Material/Parts

- Top Center Panel Screws (10)
- Top Rear Panel Screws (9)
- Left Side Panel Screws (17)
- Rear Panel Screws (14)
- Condenser Shroud Screws (2)
- Condenser Shroud Screws (6)
- Condenser Coil Screws (4)

- References**
Paragraph 5-8

Troubleshooting Reference

None

Approximate Time Required (in minutes)

Removal	30
Test	20
Repair	20
Installation	720
TOTAL TIME	790

LOCATION/ITEM

REMARKS

ACTION

REMOVAL

TOP AND LEFT SIDE OF HOUSING

1. Top Center Panel
 - a. Remove ten (10) screws securing top center panel.
 - b. Remove top center panel.

2. Top Rear Panel
 - a. Remove nine (9) screws securing top rear panel.
 - b. Remove top rear panel.

3. Left Side Panel
 - a. Remove seventeen (17) screws securing left side panel.
 - b. Remove left side panel.

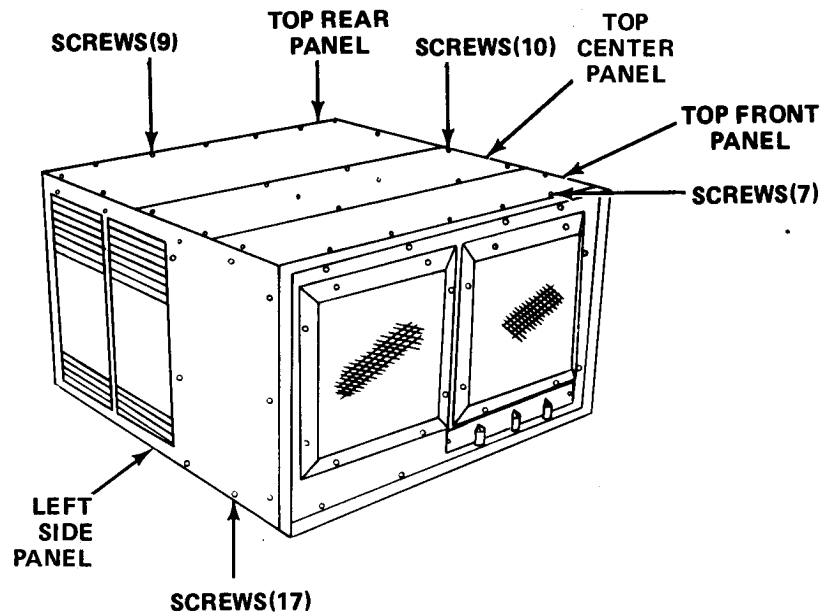

LOCATION/ITEM	REMARKS	ACTION
---------------	---------	--------

REMOVAL

REAR OF HOUSING

- | | |
|---------------|--|
| 4. Rear Panel | <ul style="list-style-type: none"> a. Remove fourteen (14) screws securing rear panel. b. Remove rear panel. |
|---------------|--|

NOTE

Test condenser coil for leaks prior to discharging refrigerant system and removing condenser coil.

- | | |
|-----------------------|--|
| 5. Refrigerant System | Refer to paragraph 5-8 and discharge refrigerant system. |
|-----------------------|--|

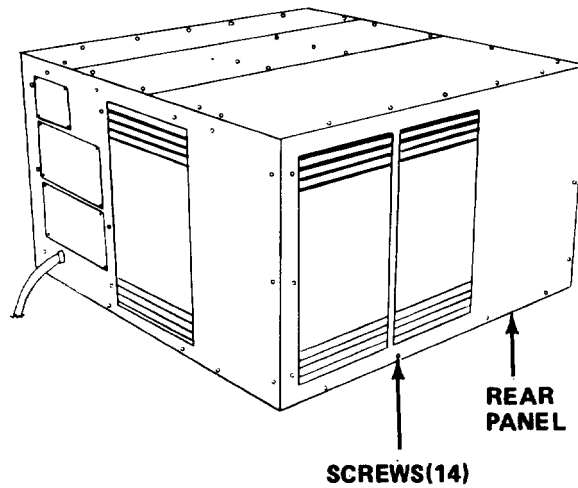

LOCATION/ITEM	REMARKS	ACTION
---------------	---------	--------

REMOVAL

HOUSING INTERIOR

6. Condenser Coil

- a. Loosen setscrew in hub of condenser fan and Slide condenser fan towards bulkhead.
- b. Remove two (2) screws securing frame to condenser shroud.
- c. Remove six (6) screws securing condenser shroud to condenser coil.
- d. Slide condenser shroud back against bulkhead.
- e. Unsolder and remove two (2) refrigerant lines from condenser coil.
- f. Remove four (4) screws from underside of base that secures condenser coil to base.
- g. Remove condenser coil.

TESTING

7. Condenser Coil

- a. Check all condenser coil tubing and sweat fittings with a General Electric Type H-2 Halogen Test Detector (or approved equal).
- b. Calibrate the detector with a General Electric LS-20 leak standard (or approved equal) for a pure refrigerant leak rate of 0.1 ounce per ear.
- c. Mark all spots where leaks are noticed.
- d. Repair leaks or replace condenser coil.

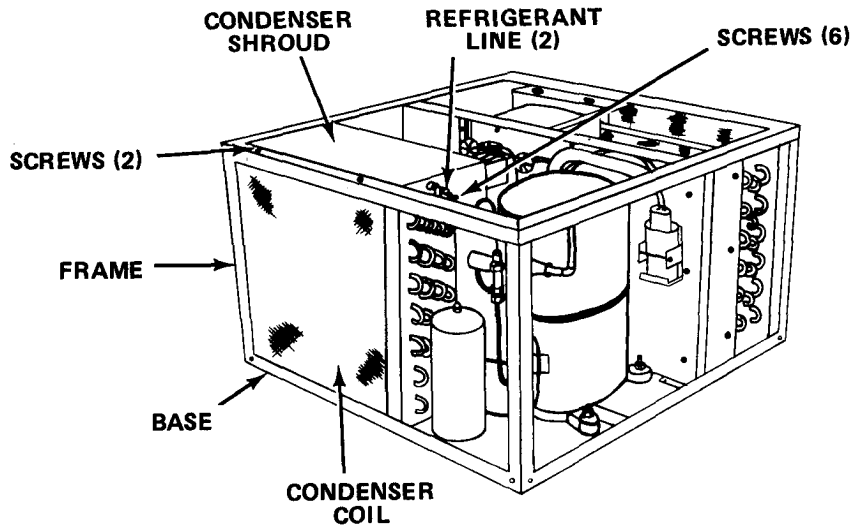

LOCATION/ITEM	REMARKS	ACTION
---------------	---------	--------

REPAIR

8. Condenser Coil

- a. Repair minor leaks or holes b soldering.
- b. Use a silver solder with a 50% silver capacity and a melting point of approximately 1160°F (634.8° C).
- c. Straighten bent fins prior to installation.

WARNING

Purge system with dry nitrogen prior to soldering. Refrigerant heated to 1200° F creates phosgene gas.

INSTALLATION

9. Condenser Coil

- a. Align holes in condenser coil with holes in base.
- b. Secure condenser coil to base from the underside with four (4) screws.
- c. Align holes in condenser shroud with holes in condenser coil.
- d. Secure condenser shroud with six (6) screws.
- e. Secure condenser shroud to frame with two (2) screws.
- f. Reposition condenser fan on motor shaft until hub is flush with end of shaft and tighten setscrew in hub.
- g. Refer to paragraph 5-8 and solder two (2) refrigerant lines to condenser coil.

INSTALLATION

REAR OF HOUSING

10. Rear Panel

- a. Align holes in rear panel with holes in housing.
- b. Secure rear panel with fourteen (14) screws.

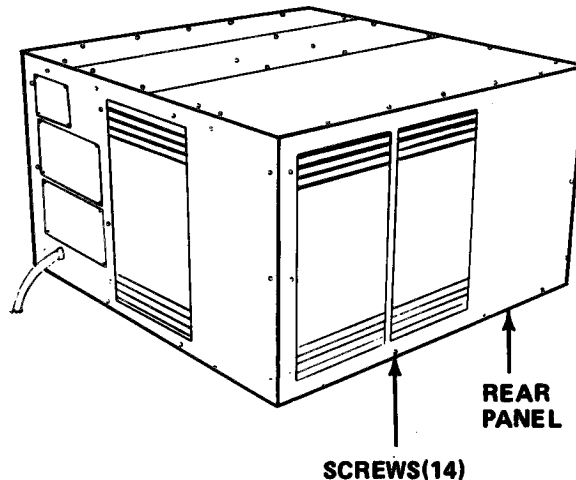

LOCATION/ITEM	REMARKS	ACTION
---------------	---------	--------

INSTALLATION

TOP AND LEFT SIDE OF HOUSING

- | | |
|---------------------------|---|
| 11. Left Side Panel | <ul style="list-style-type: none"> a. Align holes in left side panel with holes in housing. b. Secure left side panel with seventeen (17) screws. |
| 12. Top Rear Panel | <ul style="list-style-type: none"> a. Align holes in top rear panel with holes in housing. b. Secure top rear panel with nine (9) screws. |
| 13. Refrigerant Servicing | Refer to paragraph 5-8 and charge refrigerant system. |
| 14. Top Center Panel | <ul style="list-style-type: none"> a. Align holes in top center panel with holes in top front and top rear panels. b. Secure top center panel with ten (10) screws. |

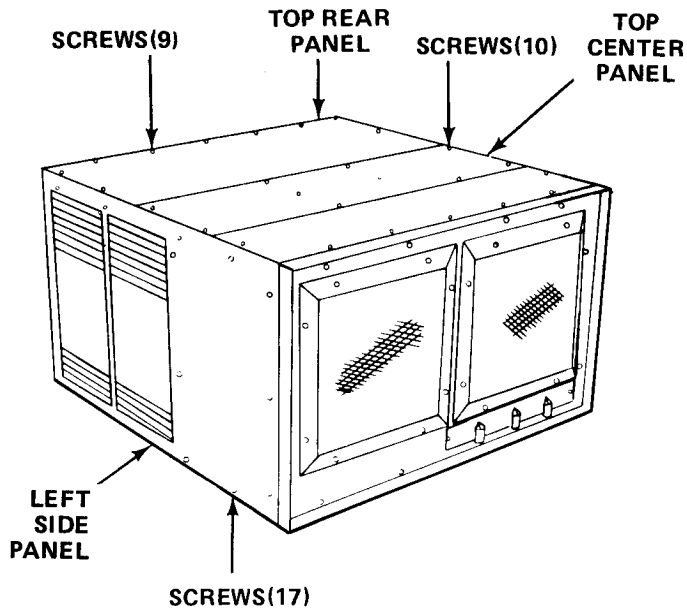

5-13. DEHYDRATOR

This task covers:

a. Removal

b. Installation

INITIAL SETUP

Material/Parts

- Right Side Panel Screws (17)
- Return Air Grill Screws (8)

Troubleshooting Reference

- AIR CONDITIONER Malfunction 3, Step 2
- AIR CONDITIONER, Malfunction 4, Step 2

Approximate Time Required (in minutes)

References	Removal	10
Paragraph 5-8	Installation	740
	TOTAL TIME	750

LOCATION/ITEM	REMARKS	ACTION
---------------	---------	--------

REMOVAL

RIGHT SIDE OF HOUSING

- | | |
|--|---|
| <p>1. Right Side Panel</p> <p>2. Return Air Grill</p> <p>3. Refrigerant System</p> | <p>a. Remove seventeen (17) screws securing right side panel to housing.</p> <p>b. Remove right side panel.</p> <p>a. Loosen setscrew and remove fresh air control knob.</p> <p>b. Remove eight (8) screws securing return air grill to front panel.</p> <p>c. Partially remove return air grill.</p> <p>Refer to paragraph 5-8 and discharge refrigerant system.</p> |
|--|---|

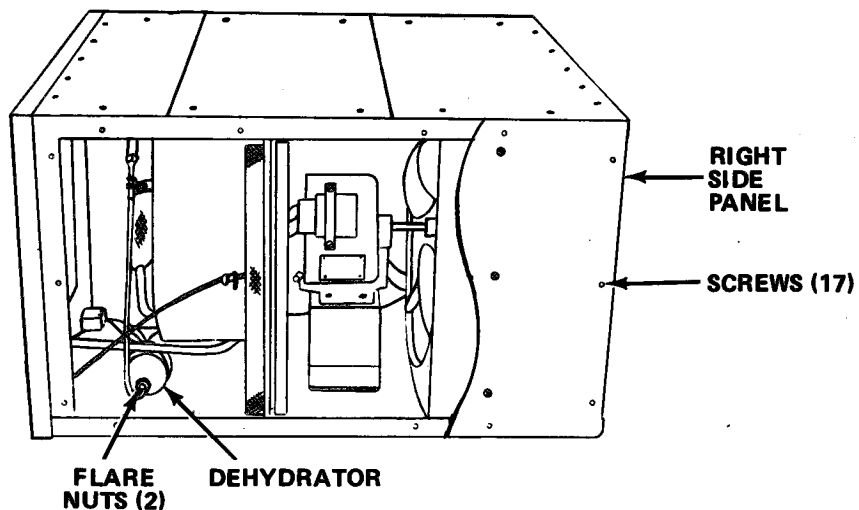

LOCATION/ITEM	REMARKS	ACTION
REMOVAL		
RIGHT SIDE OF HOUSING		
4. Dehydrator	<ul style="list-style-type: none"> a. Unscrew two (2) flare nuts and remove two (2) refrigerant lines from dehydrator. b. Remove dehydrator from air conditioner. 	
INSTALLATION		
5. Dehydrator	<ul style="list-style-type: none"> a. Connect dehydrator to two (2) refrigerant lines. b. Tighten two (2) flare nuts at dehydrator. 	
6. Right Side Panel	<ul style="list-style-type: none"> a. Align holes in right side panel with holes in housing. b. Secure right side panel with seventeen (17) screws. 	
7. Return Air Grill	<ul style="list-style-type: none"> a. Align holes in return air grill with holes in front panel. b. Secure return air grill with eight (8) screws. c. Install knob on fresh air control and tighten setscrew. 	
8. Refrigerant Servicing	<p>Refer to paragraph 5-8 and charge refrigerant system.</p>	

5-14. SIGHT GLASS

This task covers:

a. Removal

b. Installation

INITIAL SETUP

Material/Parts

Rear Panel Screws (14)

Troubleshooting Reference

None

Approximate Time Required (in minutes)

Removal	10
Installation	740
TOTAL TIME	750

References

Paragraph 5-8

LOCATION/ITEM	REMARKS	ACTION
---------------	---------	--------

REMOVAL

REAR OF HOUSING

- | LOCATION/ITEM | REMARKS | ACTION |
|-----------------------|---------|---|
| 1. Rear Panel | | a. Remove fourteen (14) screws securing rear panel to housing.
b. Remove rear panel. |
| 2. Refrigerant System | | Refer to paragraph 5-8 and discharge refrigerant system. |
| 3. Sight Glass | | a. Unscrew two (2) flare nuts and remove two (2) refrigerant lines from sight glass.
b. Remove sight glass from air conditioner. |

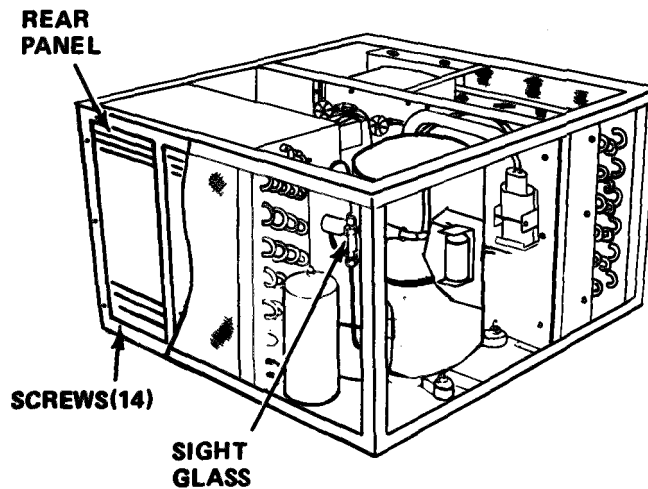

LOCATION/ITEM	REMARKS	ACTION
INSTALLATION		
REAR OF HOUSING		
4. Sight Glass		<ul style="list-style-type: none"> a. Connect sight glass to two (2) refrigerant lines. b. Tighten two (2) flare nuts at sight glass.
5. Rear Panel		<ul style="list-style-type: none"> a. Align holes in rear panel with holes in housing. b. Secure rear panel with fourteen (14) screws.
6. Refrigerant System		Refer to paragraph 5-8 and charge refrigerant system.

5-15. EXPANSION VALVE

This task Covers:

- a. Removal
- b. Test
- c. Installation

INITIAL SETUP

Material/Parts

- Top Center Panel Screws (10)
- Top Front Panel Screws (7)
- Right Side Panel Screws (17)
- Insulation Tape

Troubleshooting Reference

- AIR CONDITIONER, Malfunction 3, Step 4
- AIR CONDITIONER, Malfunction 4, Step 1
- AIR CONDITIONER, Malfunction 5, Step 3

Approximate Time Required (in minutes)

Removal	10
Test	10
Installation	730
TOTAL TIME	750

References
Paragraph 5-8

LOCATION/ITEM	REMARKS	ACTION
---------------	---------	--------

REMOVAL

TOP AND RIGHT SIDE OF HOUSING

- | | |
|--|--|
| <ol style="list-style-type: none"> 1. Top Center Panel 2. Top Front Panel 3. Right Side Panel | <ol style="list-style-type: none"> a. Remove ten (10) screws securing top center b. Remove top center panel. a. Remove seven (7) screws securing top front b. Remove top front panel. a. Remove seventeen (17) screws securing right side panel. b. Remove right side panel. |
|--|--|

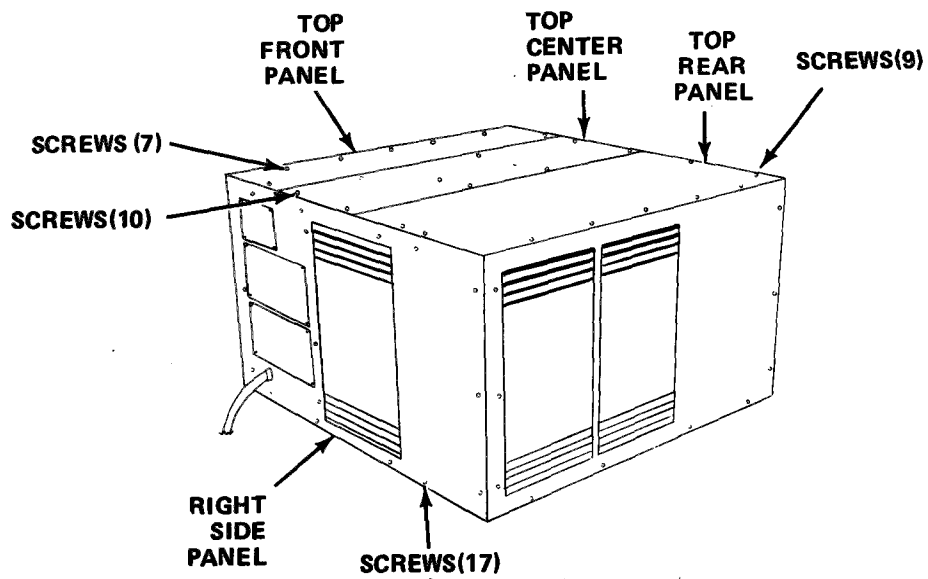

LOCATION/ITEM	REMARKS	ACTION
---------------	---------	--------

REMOVAL

TOP AND RIGHT SIDE OF HOUSING

- | | |
|---------------------|--|
| 4. Return Air Grill | <ul style="list-style-type: none"> a. Loosen setscrew and remove fresh air control knob. b. Remove eight (8) screws securing return air grill to front panel. c. Partially remove return air grill. |
|---------------------|--|

NOTE

Testing of expansion valve is to be done while the air conditioner is operating and supplying cooling air.

- | | |
|-----------------------|--|
| 5. Refrigerant System | Refer to paragraph 5-8 and discharge refrigerant system. |
|-----------------------|--|

CAUTION

Carefully unwrap thermostat switch sensing bulb from expansion valve sensing line. Use care to prevent damage to sensing bulb.

- | | |
|--------------------|---|
| 6. Expansion Valve | <ul style="list-style-type: none"> a. Unwrap insulation tape from sensing bulb. b. Mark location and remove two (2) metal straps securing sensing bulb. c. Carefully unwrap thermostat switch sensing bulb from expansion valve sensing line. d. Unscrew and remove two (2) flare nuts and remove refrigerant lines from expansion valve. e. Remove expansion valve. |
|--------------------|---|

TESTING

- | | |
|--------------------|---|
| 7. Expansion Valve | <ul style="list-style-type: none"> a. Using a General Electric Type H-2 Halogen Test Detector (or approved equal), check expansion valve for leaks. b. Calibrate the detector with a General Electric LS-20 leak standard (or approved equal) for a pure refrigerant leak rate of 0.1 ounce per year. c. Verify that there is NO leakage or damage. d. Replace expansion valve if testing indicates that it is defective. |
|--------------------|---|

INSTALLATION

- | | |
|--------------------|--|
| 8. Expansion Valve | <ul style="list-style-type: none"> a. Connect expansion valve to refrigerant lines. b. Tighten two (2) flare nuts. c. Secure sensing bulb to refrigerant line with two (2) metal straps. d. Carefully wrap insulation tape No. 165 manufactured by Pressite Division, Inmont Inc., St Louis, MO, around sensing bulb and refrigerant line. Completely cover sensing bulb with tape. e. Carefully wrap thermostat switch sensing bulb around expansion valve sensing line in the same location that it was removed from. |
|--------------------|--|

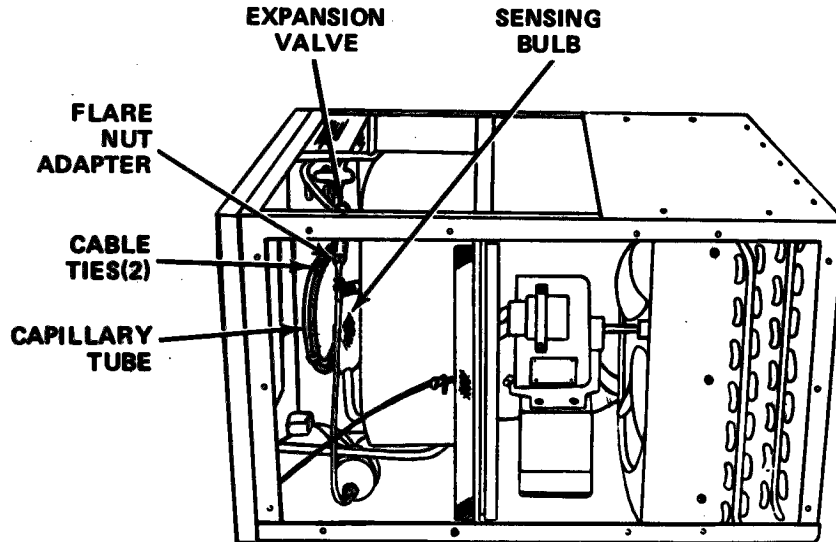

LOCATION/ITEM	REMARKS	ACTION
---------------	---------	--------

INSTALLATION

TOP AND RIGHT SIDE OF HOUSING

- | | |
|----------------------|---|
| 9. Return Air Grill | <ul style="list-style-type: none"> a. Align holes in return air grill with holes in front panel. b. Secure return air grill to front panel with eight (8) screws. |
| 10. Right Side Panel | <ul style="list-style-type: none"> a. Align holes in right side panel with holes in housing. b. Secure right side panel with seventeen (17) screws. |
| 11. Top Front Panel | <ul style="list-style-type: none"> a. Align holes in top front panel with holes in housing. b. Secure top front panel with seven (7) screws. |

LOCATION/ITEM	REMARKS	ACTION
---------------	---------	--------

INSTALLATION

TOP AND RIGHT SIDE OF HOUSING

12. Refrigerant Servicing

Refer to paragraph 5-8 and charge refrigerant system.

13. Top Center Panel

- a. Align holes in top center panel with holes in top front and top rear panels.
- b. Secure top center panel with ten (10) screws.

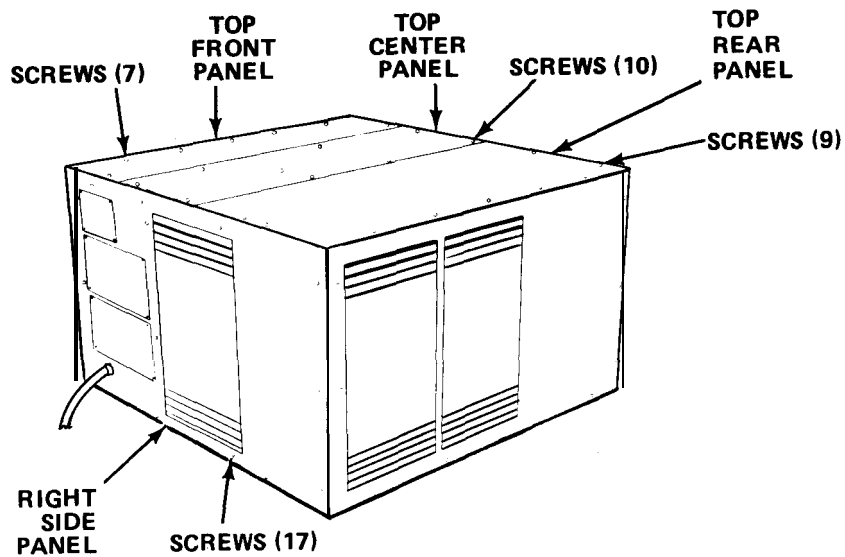

APPENDIX A REFERENCES

A-1. FIRE PROTECTION

TB 5-4200-200-10 Hand Portable Fire Extinguishers Approved for Army Users

A-2. LUBRICATION

C91001L Fuels, Lubricants, Oil and Waxes

A-3. PAINTING

TM-43-0139 Painting Instructions for Field Use

A-4. MAINTENANCE

TM 38-750 The Army Maintenance Management System (TAMMS)
 TM 5-4120-341-23P Organizational and Direct Support Maintenance Repair Parts and Special
 Tools List

A-5. CLEANING

Fed Spec P-S-661 Dry Cleaning Solvent
 Fed Spec P-D-680 Dry Cleaning Solvent

A-6. DESTRUCTION

TM 750-244-3 Procedures for Destruction of Equipment to Prevent Enemy Use

A-7. SHIPMENT AND STORAGE

TM 740-90-1 Administrative Storage of Equipment

A-8. RADIO SUPPRESSION

FM 11-65 Radio Interference Suppression

APPENDIX B

COMPONENTS OF END ITEMS LIST

Section I. INTRODUCTION

B-1. SCOPE

This appendix lists Integral Components of and Basic Issue Items (BII) for the air conditioner to help you inventory items required for safe and efficient operation.

B-2. GENERAL

The components of end item list are divided into the following sections:

a. Section II. Integral Components of the End Item. These items, when assembled, comprise the air conditioner and must accompany it whenever it is transferred or turned in. These illustrations will help you identify these items.

b. Section III. Basic Issue Items. These are minimum essential items required to place the air conditioner in operation, to operate it and to perform emergency repairs. Although shipped separately packed, they must accompany the air conditioner during operation and whenever it is transferred between accountable officers. The illustrations will assist you with hard-to-identify items. This manual is your authority to requisition replacement BII based on Table(s) of Organization and Equipment (TOE)/Modification Table of Organization and Equipment (MTOE) authorization of the end item.

B-3. EXPLANATION OF COLUMNS

a. Illustration. This column is divided as follows:

(1) *Figure Number.* Indicates the figure number of the illustration on which the item is shown (if applicable).

(2) *Item Number.* The number used to identify item called out in the illustration.

b. National Stock Number (NSN). Indicates the national stock number assigned to the end item which will be used for requisitioning.

c. Part Number (P/N). Indicates the primary number used by the manufacturer which controls the design and characteristics of the item by means of its engineering drawings, specifications, standards and inspection requirements to identify an item or range of items.

d. Description. Indicates the federal item name and, if required, a minimum description to identify the item.

e. Location. The physical location of each item listed is given in this column. The lists are designed to inventory all items in one area of the major item before moving on to an adjacent area.

f. Usable on Code. "Usable On" codes are included to help you identify which component items are used on the different models. Identification of the codes used in this list are:

Code	Used On
-------------	----------------

Not Applicable

g. Quantity Required (Qty Reqd). This column lists the quantity of each item required for a complete major item.

h. Quantity. This column is left blank for use during inventory. Under the received column, list the quantity you actually receive on your major item. The date columns are for use when you inventory the major item at a later date, such as for shipment to another site.

APPENDIX C

MAINTENANCE ALLOCATION CHART

Section I. INTRODUCTION.

C-1. GENERAL

a. This section provides a general explanation of all maintenance and repair functions authorized at various maintenance levels.

b. Section II designates overall responsibility for the performance of maintenance functions on the identified end item or component and the work measurement time required to perform the functions by the designated maintenance level. The implementation of the maintenance functions upon the end item or components will be consistent with the assigned maintenance functions.

c. Section III lists the tools and test equipment required for each maintenance function as referenced from Section II (Not Applicable).

C-2. EXPLANATION OF COLUMNS IN SECTION II

a. *Column (1), Group Number.* Column 1 lists group numbers to identify related components, assemblies, subassemblies, and modules with their next higher assembly. The applicable groups are listed in the MAC in disassembly sequence beginning with the first group removed.

b. *Column (2), Component/Assembly.* This column contains the noun names of components, assemblies, subassemblies and modules for which maintenance is authorized.

c. *Column (3), Maintenance Functions.* This column lists the functions to be performed on the item listed in Column 2. The maintenance functions are defined as follows:

(1) *Inspect.* To determine serviceability of an item by comparing its physical, mechanical, or electrical characteristics with established standards through examination.

(2) *Test.* To verify serviceability and to detect incipient failure by measuring the mechanical or electrical characteristics of an item, and comparing those characteristics with prescribed standards.

(3) *Service.* Operations required periodically to keep an item in proper operating condition, i.e., to clean (decontaminate), to preserve, to drain, to paint, or to replenish fuel, lubricants, hydraulic fluids, or compressed air supplies.

(4) *Adjust.* To maintain within prescribed limits, by bringing into proper or exact position, or by setting the operating characteristics to specified parameters.

(5) *Align.* To adjust specified variable elements of an item to bring about optimum or desired performance.

(6) *Calibrate.* To determine and cause corrections to be made or to be adjusted on instruments or test measuring and diagnostic equipments used in precision measurement. Consist of comparison of two instruments, one of which is a certified standard of known accuracy, to detect and adjust any discrepancy in the accuracy of the instrument being compared.

(7) *Install.* The act of emplacing, seating or fixing into position an item, part or module (component or assembly) in a manner to allow the proper functioning of an equipment or system.

(8) *Rep/ace.* The act of substituting a serviceable like type part, subassembly or module (component or assembly) for an unserviceable counterpart.

(9) *Repair*. The application of maintenance services (inspect, test, service, adjust, align, calibrate or replace) or other maintenance actions (welding, grinding, riveting, straightening, facing remachining or resurfacing) to restore serviceability to an item by correcting specific damage, fault, malfunction, or failure in a part, sub-assembly, module (component or assembly), end item, or system.

(10) *Overhaul*. That maintenance effort (service/action) necessary to restore an item to a completely serviceable/operational condition as prescribed by maintenance standards in appropriate technical manuals, Overhaul is normally the highest degree of maintenance performed by the Army. Overhaul does not normally return an item to a like new condition.

(11) *Rebuild*. Consists of those services/actions necessary for the restoration of unserviceable equipment to a like new condition in accordance with original manufacturing standards. Rebuild is the highest degree of material maintenance applied to Army equipment. The rebuild operation includes the act of returning to zero those age measurements (hours/miles, etc.) considered in classifying Army equipments/components.

d. *Column (4), Maintenance Level*. This column is made up of sub-columns for each category of maintenance. Work time figures are listed in these sub-columns for the lowest level of maintenance authorized to perform the function listed in column 3. These figures indicate the average active time required to perform the maintenance function at the indicated category of maintenance under typical field operating conditions.

e. *Column (5), Tool and Equipment*. This column is provided for referencing by code, the common tool sets (not individual tools) special tools, test and support equipment required to perform the designated functions (Not Applicable).

Section II. MAINTENANCE ALLOCATION CHART
FOR
9,000 BTU/HR Conventional Air Conditioner

(1) GROUP NUMBER	(2) COMPONENT ASSEMBLY	(3) MAINTENANCE FUNCTION	(4) MAINTENANCE LEVEL					(5) TOOLS AND EQUIPMENT
			C	O	F	H	D	
01	HOUSING							
	Panels, Grills	Inspect	X					
		Repair		X				
		Replace		X				
02	Drains	Adjust	X					
		Service	X					
	Inspect	Inspect	X					
		Service	X					
03	FILTER							
	Air Filter	Inspect						
		Service						
Replace								
04	ELECTRIC MOTOR AND FANS	Motor	Inspect					
			Test					
			Repair					
	Fans	Replace						
		Inspect						
		Repair						
STARTING AND PROTECTIVE DEVICE	Switches	Replace						
		Inspect	X					
	Capacitors	Test						
		Replace						
Start Relay	Test							
	Replace							

* Subcolumns are as follows:
F-Direct Support;

C-Operator/Crew;
H-General Support;

O-Organizational;
D-Depot.

** Indicates WT/MH Required.

Section II. MAINTENANCE ALLOCATION CHART
FOR
9,000 BTU/HR Conventional Air Conditioner

(1) GROUP NUMBER	(2) COMPONENT ASSEMBLY	(3) MAINTENANCE FUNCTION	(4) MAINTENANCE LEVEL					(5) TOOLS AND EQUIPMENT
			C	O	F	H	D	
05	WIRING							
	Misc. Wiring	Inspect Test Repair Replace		X X X X				
06	GAS COMPRESSOR, PIPING AND COMPONENTS							
	Compressor	Inspect (1) Test Service Repair Replace		X	X X X X			
	Refrigerant Piping and Service Valves	Inspect (1) Test Repair Replace		X	X X X			
	Evaporator Coil	Inspect Service Test Repair Replace		X X	X X X			
	Condensor Coil	Inspect Service Test Repair Replace		X X	X X X			
	Dehydrator	Replace			X			
	Sight Glass	Inspect Replace		X	X			
	Expansion Valve	Inspect Test Replace		X	X X			

* Subcolumns are as follows:
F-Direct Support;

C-Operator/Crew;
H-General Support;

O-Organizational;
D-Depot.

** Indicates WT/MH Required.

APPENDIX C

**Section III. TOOL AND TEST EQUIPMENT REQUIREMENTS
MAINTENANCE ALLOCATION CHART**

(1) Reference Code	(2) Maintenance Level	(3) Nomenclature	(4) National/NATO stock number	(5) Tool Number
1	O-F-H	Soldering Gun Kit	3439-00-930-1638	
2	F-H	Recovery and Recycling Unit, Refrigerant	4130-01-338-2707	17500B (07295)

APPENDIX C

**Section IV. REMARKS
MAINTENANCE ALLOCATION CHART**

Reference Code	REMARKS
Note 1	Inspect components externally only.

APPENDIX D
ADDITIONAL AUTHORIZATION LIST
Section I. INTRODUCTION

D-1. SCOPE

This appendix lists additional items you are authorized for the support of the air conditioner.

D-2. GENERAL

This list identifies items that do not have to accompany the air conditioner and that do not have to be turned in with it. These items are authorized to you by CTA, MTOE, TDA or JTA.

D-3. EXPLANATION OF LISTING

National stock number, descriptions, and quantities are provided to help you identify and request the additional items you require to support this equipment. "USABLE ON" codes are identified as follows:

code	Used On
	Not Applicable

APPENDIX E

EXPENDABLE SUPPLIES AND MATERIAL LIST

Section I. INTRODUCTION

E-1. SCOPE

This appendix lists expendable supplies and materials you will need to operate and maintain the air conditioner.

These items are authorized to you by CTA 50-970, Expendable Items (Except Medical, Class V, Repair Parts and Heraldic Items).

E-2. EXPLANATION OF COLUMNS

a. Column 1, Item Number. This number is assigned to the entry in the listing and is referenced in the narrative instructions to identify the material (e.g., "Use cleaning compound, item 5, App. D").

b. Column 2, Level. This column identifies the lowest level of maintenance that requires the listed item.

- C - Operator/Crew
- O - Organizational Maintenance
- F - Direct Support Maintenance
- H - General Support Maintenance

c. Column 3, National Stock Number. This is the National stock number assigned to the item; use it to request or requisition the item.

d. Column 4, Description. Indicates the Federal item name and, if required, a description to identify the item. The last line for each item indicates the part number followed by the Federal Supply Code for Manufacturer (FSCM) in parenthesis, if applicable.

e. Column 5, Unit of Measure (U/M). Indicates the measure used in performing the actual maintenance function. This measure is expressed by a two-character alphabetical abbreviation (e.g., ea, in, pr). If the unit of measure differs from the unit of issue, requisition the lowest unit of issue that will satisfy your requirements.

Section II. EXPENDABLE SUPPLIES AND MATERIALS

(1) ITEM NUMBER	(2) LEVEL	(3) NATIONAL STOCK NUMBER	(4) DESCRIPTION	(5) U/M
1	0		Coater, Air Filter	
2	0		Dry Cleaning Solvent, P-D-680	
3	0		Dry Cleaning Solvent, P-S-661	
4	0		Adhesive	
			NOTE	
5	F		Whenever available, use recycled refrigerant for charging the refrigeration system. Refrigerant	

APPENDIX F

DIAGRAMS

F-1. WIRING DIAGRAM

The wiring diagram for the air conditioner is shown in figure F-1.

F-2. REFRIGERANT SYSTEM DIAGRAM

The refrigerant system diagram for the air conditioner is shown in figure F-2.

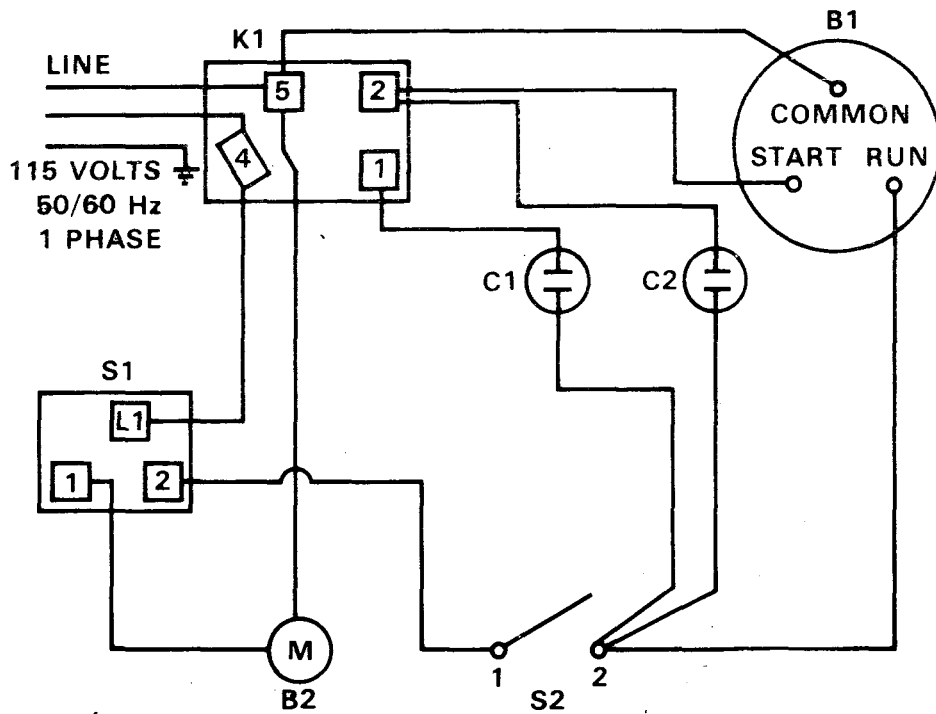

COMPONENT REFERENCE LIST		
REF DES	DESCRIPTION	PART NO.
S1	SELECTOR SWITCH	13221E4549
B1	COMPRESSOR	13221E4551
S2	THERMOSTAT	13221E4554
C2	RUN CAPACITOR	R612-103
C1	START CAPACITOR	13221E4581
K1	START RELAY	13221E4582
B2	A.C. MOTOR	13221E4583

TS-4120-341-13/F-1

Figure F-1. Wiring diagram, single phase, 50/60 cycle, 115 volts.

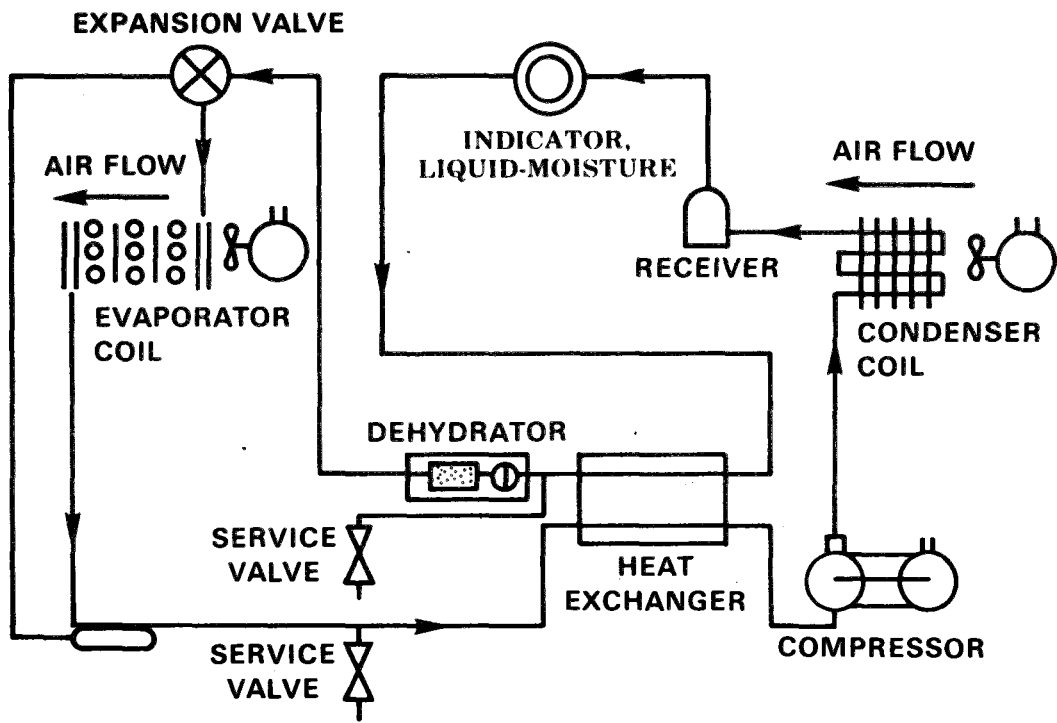

COMPONENT REFERENCE LIST	
DESCRIPTION	PART NO.
COMPRESSOR	13221E4551
CONDENSER COIL	13221E4534
EVAPORATOR COIL	13221E4535
EXPANSION VALVE	13221E4574
DEHYDRATOR	13214E3557
RECEIVER	13221E4538
SERVICE VALVE	13219E9499
SERVICE VALVE	13219E9499
INDICATOR, LIQUID-MOISTURE	13221E4548

REFRIGERANT CHARGE
3 lb R 12

TS-4120-341-13/F-2

Figure F-2. Refrigeration diagram.

INDEX

Paragraph,
Figure, Table
Number

Subject

A

Air Diffuser and Return Air Grills 3-6
 Air Filter 4-19
 Assembly and Preparation for Typical Use..... 4-6

C

Circulating Fan 4-22
 Common Tools and Equipment 4-2,5-2
 Compressor 4-30,5-9
 Condenser coil 4-33,5-12
 Condenser Fan 4-21
 Consumable Materials 4-4,5-4
 Control Panel Switches 3-8
 Cooling 1-13

D

Dehydrator 5-13
 Destruction of Army Material to Prevent Enemy Use 1-3
 Differences Between Models 1-9
 Direct Support Troubleshooting Table 5-6
 Drains 3-7

E

Evaporator Coil 4-32,5-11
 Expansion Valve 4-35,5-15

F

Fan Motor 4-20
 Fan Rotation Check 4-11

H

Hand Receipt 1-6
 Housing Panels 3-5
 Housing Panels and Grills 4-18

I

Initial Adjustments 4-10

L

List of Abbreviations 1-5
 Lubrication 3-1

M

Maintenance Forms and Records 1-2
 Maintenance Repair Parts 4-1
 Motor Capacitor 4-25
 Mount the Unit 4-8

O

Operating instructions on Decals and Instruction Plates 2-7
 Operating Procedures 2-3
 Operation Under Unusual Conditions
 Dusty or Sandy Areas 2-9
 Extreme Heat 2-8
 Rainy or Humid Conditions 2-10
 Saltwater Areas 2-11
 Operator/Crew Preventive Maint. Checks and service 4-16
 Organizational Troubleshooting Table 4-16

P

Performance Data
 Direct Support Maintenance 1-11
 Organizational Maintenance 1-10
 Position the Unit 4-7
 Power Source, Connect 4-9
 Preventive Maintenance Checks and Services (PMCS) 4-14
 Purpose of Air Conditioner. 1-7

R

Refrigerant
 Piping 4-31
 Piping and Service Valves 5-10
 Servicing 5-8
 Reporting Equipment Improvements Recommendation (RIPS) 1-4
 Return Air Grill check 4-12
 Run Capacitor 4-27

S

Selector Switch 4-23
 Service Upon REceipt Checklist 4-5
 Sight Glass 4-34, 5-14
 Special Tools and Test Equipment 4-3, 5-3
 Start Capacitor 4-26
 Start Relay 4-28
 Starting
 Operating instructions for Cooling 2-4
 Operating instructions for Ventilation 2-5
 Stopping Instructions 2-6

T

Thermostat Switch 4-24
 Troubleshooting Table 3-3

V

Ventilation 1-14

W

Wiring 4-29

By Order of the Secretary of the Army:

E. C. MEYER
General, United States Army
Chief of Staff

Official:

J. C. PENNINGTON
Major General, United State Army
The Adjutant General

DISTRIBUTION:

To be distributed in accordance with DA Form 12-25C, Operator Maintenance requirements for Environmental Equipment, Air Conditioners, 9,000 BTU.

RECOMMENDED CHANGES TO EQUIPMENT TECHNICAL PUBLICATIONS



THEN... JOT DOWN THE DOPE ABOUT IT ON THIS FORM. CAREFULLY TEAR IT OUT. FOLD IT AND DROP IT IN THE MAIL!

SOMETHING WRONG WITH THIS PUBLICATION?

FROM: (PRINT YOUR UNIT'S COMPLETE ADDRESS)

PFC JOHN DOE
COA, 3d ENGINEER BN
FT. LEONARD WOOD, MO 63108

DATE SENT

PUBLICATION NUMBER

TM 5-4120-341-13

PUBLICATION DATE

13 Mar 81

PUBLICATION TITLE

Air Conditioner 9,000 BTU/HR
Hottel Model HAC-751

BE EXACT... PIN-POINT WHERE IT IS

PAGE NO.	PARA-GRAPH	FIGURE NO.	TABLE NO.
6	2-1 a		
B1		4-3	
125	line 20		

IN THIS SPACE TELL WHAT IS WRONG AND WHAT SHOULD BE DONE ABOUT IT:

In line 6 of paragraph 2-1a the manual states the engine has 6 cylinders. The engine on my set only has 4 cylinders. Change the manual to show 4 cylinders.

Callout 16 on figure 4-3 is pointing at a bolt. In key to figure 4-3, item 16 is called a shim - Please correct one or the other.

I ordered a gasket, item 19 on figure B-16 by NSN 2 910-05-762-3001. I got a gasket but it doesn't fit. Supply says I got what I ordered, so the NSN is wrong. Please give me a good NSN

PRINTED NAME, GRADE OR TITLE, AND TELEPHONE NUMBER

JOHN DOE, PFC (268) 317-7111

SIGN HERE:

JOHN DOE

DA FORM 2028-2
1 JUL 79

PREVIOUS EDITIONS ARE OBSOLETE.
DRSTS-M Overprint 1, 1 Nov 80

P.S.--IF YOUR OUTFIT WANTS TO KNOW ABOUT YOUR RECOMMENDATION MAKE A CARBON COPY OF THIS AND GIVE IT TO YOUR HEADQUARTERS.

TEAR ALONG PERFORATED LINE

FILL IN YOUR
UNIT'S ADDRESS

FOLD BACK

DEPARTMENT OF THE ARMY

OFFICIAL BUSINESS
PENALTY FOR PRIVATE USE \$300

POSTAGE AND FEES PAID
DEPARTMENT OF THE ARMY
DOD 314



COMMANDER
U S ARMY SUPPORT AND AVIATION MATERIEL READINESS COMMAND
ATTN: DRSTS-MTT
4300 GOODFELLOW BOULEVARD
ST. LOUIS, MO 63120

TEAR ALONG PERFORATED LINE

RECOMMENDED CHANGES TO EQUIPMENT TECHNICAL PUBLICATIONS



THEN... JOT DOWN THE DOPE ABOUT IT ON THIS FORM. CAREFULLY TEAR IT OUT, FOLD IT AND DROP IT IN THE MAIL!

SOMETHING WRONG WITH THIS PUBLICATION?

FROM: (PRINT YOUR UNIT'S COMPLETE ADDRESS)

DATE SENT

PUBLICATION NUMBER

TM 5-4120-341-13

PUBLICATION DATE

13 Mar 81

PUBLICATION TITLE

Air Conditioner 9,000 BTU/HR
Hottel Model HAC-751

BE EXACT... PIN-POINT WHERE IT IS

PAGE NO.	PARA-GRAPH	FIGURE NO.	TABLE NO.

IN THIS SPACE TELL WHAT IS WRONG AND WHAT SHOULD BE DONE ABOUT IT:

TEAR ALONG PERFORATED LINE

PRINTED NAME, GRADE OR TITLE, AND TELEPHONE NUMBER

SIGN HERE:

DA FORM 2028-2
1 JUL 79

PREVIOUS EDITIONS ARE OBSOLETE.
DRSTS-M Overprint 2, 1 Nov 80.

P.S.--IF YOUR OUTFIT WANTS TO KNOW ABOUT YOUR RECOMMENDATION MAKE A CARBON COPY OF THIS AND GIVE IT TO YOUR HEADQUARTERS.

FILL IN YOUR
UNIT'S ADDRESS

FOLD BACK

DEPARTMENT OF THE ARMY

OFFICIAL BUSINESS
PENALTY FOR PRIVATE USE \$300

POSTAGE AND FEES PAID
DEPARTMENT OF THE ARMY
DOD 314



TEAR ALONG PERFORATED LINE

COMMANDER
U S ARMY SUPPORT AND AVIATION MATERIEL READINESS COMMAND
ATTN: DRSTS-MTT
4300 GOODFELLOW BOULEVARD
ST. LOUIS, MO 63120

RECOMMENDED CHANGES TO EQUIPMENT TECHNICAL PUBLICATIONS



THEN... JOT DOWN THE DOPE ABOUT IT ON THIS FORM, CAREFULLY TEAR IT OUT, FOLD IT AND DROP IT IN THE MAIL!

SOMETHING WRONG WITH THIS PUBLICATION?

FROM: (PRINT YOUR UNIT'S COMPLETE ADDRESS)

DATE SENT

PUBLICATION NUMBER

TM 5-4120-341-13

PUBLICATION DATE

13 Mar 81

PUBLICATION TITLE

Air Conditioner 9,000 BTU/HR
Hottel Model HAC-751

BE EXACT... PIN-POINT WHERE IT IS

PAGE NO.	PARA-GRAPH	FIGURE NO.	TABLE NO.
----------	------------	------------	-----------

IN THIS SPACE TELL WHAT IS WRONG AND WHAT SHOULD BE DONE ABOUT IT:

TEAR ALONG PERFORATED LINE

PRINTED NAME, GRADE OR TITLE, AND TELEPHONE NUMBER

SIGN HERE:

DA FORM 1 JUL 79 2028-2

PREVIOUS EDITIONS ARE OBSOLETE.
DRSTS-M Overprint 2, 1 Nov 80.

P.S.--IF YOUR OUTFIT WANTS TO KNOW ABOUT YOUR RECOMMENDATION MAKE A CARBON COPY OF THIS AND GIVE IT TO YOUR HEADQUARTERS.

FILL IN YOUR
UNIT'S ADDRESS

FOLD BACK

DEPARTMENT OF THE ARMY

OFFICIAL BUSINESS
PENALTY FOR PRIVATE USE \$300

POSTAGE AND FEES PAID
DEPARTMENT OF THE ARMY
DOD 314



COMMANDER
U S ARMY SUPPORT AND AVIATION MATERIEL READINESS COMMAND
ATTN: DRSTS-MTT
4300 GOODFELLOW BOULEVARD
ST. LOUIS, MO 63120

TEAR ALONG PERFORATED LINE

RECOMMENDED CHANGES TO EQUIPMENT TECHNICAL PUBLICATIONS



THEN... JOT DOWN THE DOPE ABOUT IT ON THIS FORM. CAREFULLY TEAR IT OUT. FOLD IT AND DROP IT IN THE MAIL!

SOMETHING WRONG WITH THIS PUBLICATION?

FROM: (PRINT YOUR UNIT'S COMPLETE ADDRESS)

DATE SENT

PUBLICATION NUMBER

PUBLICATION DATE

PUBLICATION TITLE

TM 5-4120-341-13

13 Mar 81

Air Conditioner 9,000 BTU/HR
Hottel Model HAC-751

BE EXACT... PIN-POINT WHERE IT IS

IN THIS SPACE TELL WHAT IS WRONG AND WHAT SHOULD BE DONE ABOUT IT:

PAGE NO.

PARA-GRAPH

FIGURE NO.

TABLE NO.

TEAR ALONG PERFORATED LINE

PRINTED NAME, GRADE OR TITLE, AND TELEPHONE NUMBER

SIGN HERE:

DA FORM 2028-2
1 JUL 79

PREVIOUS EDITIONS ARE OBSOLETE.
DRSTS-M Overprint 2, 1 Nov 80.

P.S.--IF YOUR OUTFIT WANTS TO KNOW ABOUT YOUR RECOMMENDATION MAKE A CARBON COPY OF THIS AND GIVE IT TO YOUR HEADQUARTERS.

FILL IN YOUR
UNIT'S ADDRESS

FOLD BACK

DEPARTMENT OF THE ARMY

OFFICIAL BUSINESS
PENALTY FOR PRIVATE USE \$300

POSTAGE AND FEES PAID
DEPARTMENT OF THE ARMY
DOD 314



COMMANDER
U S ARMY SUPPORT AND AVIATION MATERIEL READINESS COMMAND
ATTN: DRSTS-MTT
4300 GOODFELLOW BOULEVARD
ST. LOUIS, MO 63120

TEAR ALONG PERFORATED LINE

The Metric System and Equivalents

Linear Measure

1 centimeter = 10 millimeters = .39 inch
 1 decimeter = 10 centimeters = 3.94 inches
 1 meter = 10 decimeters = 39.37 inches
 1 dekameter = 10 meters = 32.8 feet
 1 hectometer = 10 dekameters = 328.08 feet
 1 kilometer = 10 hectometers = 3,280.8 feet

Weights

1 centigram = 10 milligrams = .15 grain
 1 decigram = 10 centigrams = 1.54 grains
 1 gram = 10 decigrams = .035 ounce
 1 dekagram = 10 grams = .35 ounce
 1 hectogram = 10 dekagrams = 3.52 ounces
 1 kilogram = 10 hectograms = 2.2 pounds
 1 quintal = 100 kilograms = 220.46 pounds
 1 metric ton = 10 quintals = 1.1 short tons

Liquid Measure

1 centiliter = 10 milliliters = .34 fl. ounce
 1 deciliter = 10 centiliters = 3.38 fl. ounces
 1 liter = 10 deciliters = 33.81 fl. ounces
 1 dekaliter = 10 liters = 2.64 gallons
 1 hectoliter = 10 dekaliters = 26.42 gallons
 1 kiloliter = 10 hectoliters = 264.18 gallons

Square Measure

1 sq. centimeter = 100 sq. millimeters = .155 sq. inch
 1 sq. decimeter = 100 sq. centimeters = 15.5 sq. inches
 1 sq. meter (centare) = 100 sq. decimeters = 10.76 sq. feet
 1 sq. dekameter (are) = 100 sq. meters = 1,076.4 sq. feet
 1 sq. hectometer (hectare) = 100 sq. dekameters = 2.47 acres
 1 sq. kilometer = 100 sq. hectometers = .386 sq. mile

Cubic Measure

1 cu. centimeter = 1000 cu. millimeters = .06 cu. inch
 1 cu. decimeter = 1000 cu. centimeters = 61.02 cu. inches
 1 cu. meter = 1000 cu. decimeters = 35.31 cu. feet

Approximate Conversion Factors

To change	To	Multiply by	To change	To	Multiply by
inches	centimeters	2.540	ounce-inches	newton-meters	.007062
feet	meters	.305	centimeters	inches	.394
yards	meters	.914	meters	feet	3.280
miles	kilometers	1.609	meters	yards	1.094
square inches	square centimeters	6.451	kilometers	miles	.621
square feet	square meters	.093	square centimeters	square inches	.155
square yards	square meters	.836	square meters	square feet	10.764
square miles	square kilometers	2.590	square meters	square yards	1.196
acres	square hectometers	.405	square kilometers	square miles	.386
cubic feet	cubic meters	.028	square hectometers	acres	2.471
cubic yards	cubic meters	.765	cubic meters	cubic feet	35.315
fluid ounces	milliliters	29.573	cubic meters	cubic yards	1.308
pints	liters	.473	milliliters	fluid ounces	.034
quarts	liters	.946	liters	pints	2.113
gallons	liters	3.785	liters	quarts	1.057
ounces	grams	28.349	liters	gallons	.264
pounds	kilograms	.454	grams	ounces	.035
short tons	metric tons	.907	kilograms	pounds	2.205
pound-feet	newton-meters	1.365	metric tons	short tons	1.102
pound-inches	newton-meters	.11375			

Temperature (Exact)

°F	Fahrenheit temperature	5/9 (after subtracting 32)	Celsius temperature	°C
----	------------------------	----------------------------	---------------------	----

